

TYPE



BKM HELICAL-HYPOID GEAR UNITS



BKM..C(MV)



BKM..C(IEC)



BKM..B(ST)

STRUCTURE DIAGRAM

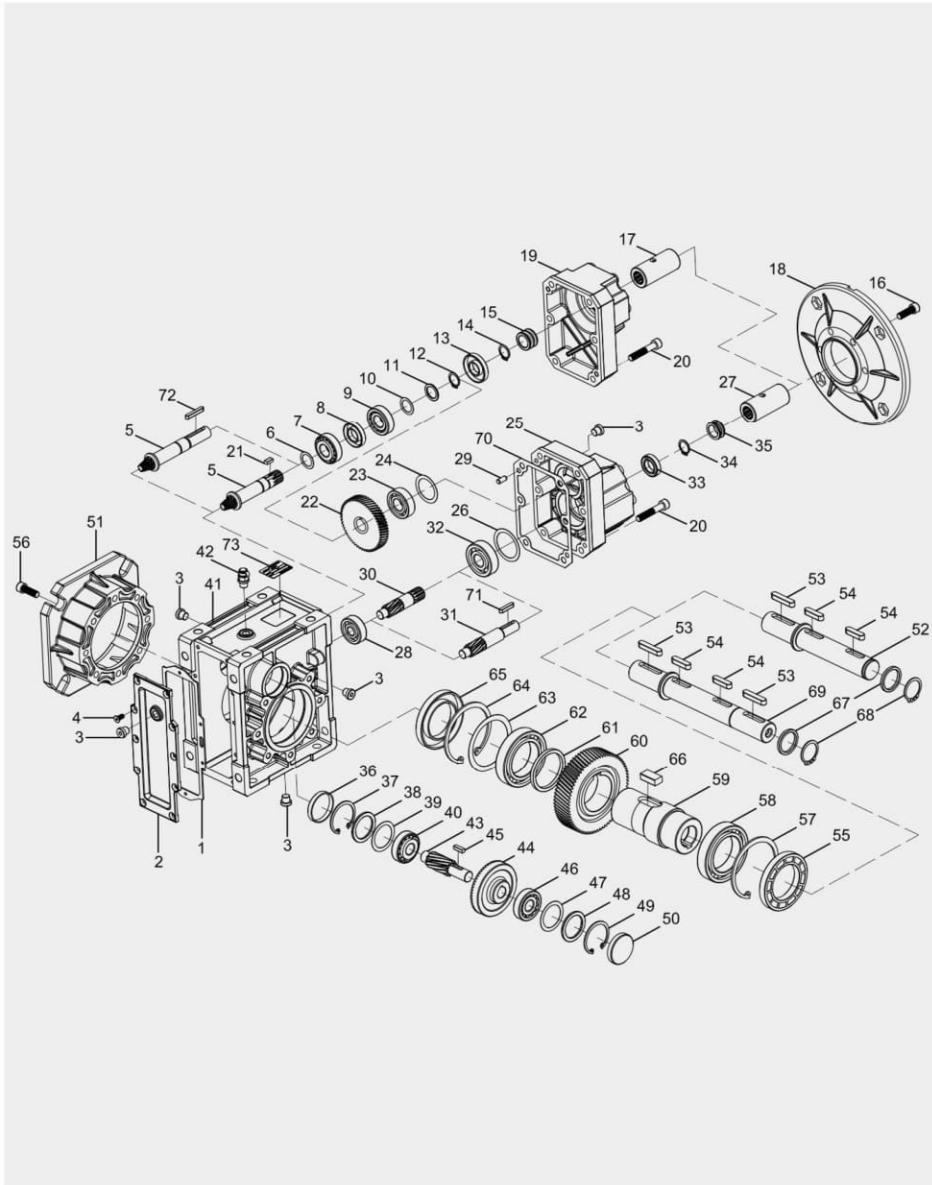

STRUCTURE DIAGRAM

1	Rubber gasket	38	Washer
2	Gearcase cover	39	Shim ring
3	Oil plug	40	Bearing
4	Hexagon sunk screw	41	Gearcase
5	Pinion shaft	42	Breather valve
6	Shin ring	43	Pinion shaft
7	Bearing	44	Gear
8	Oil seal	45	Key
9	Bearing	46	Bearing
10	Shin ring	47	Shim ring
11	Washer	48	Washer
12	Shaft-circlip	49	Hole-circlip
13	Oil seal	50	Closing cap
14	Shaft-circlip	51	Output flange
15	Rubber boot	52	Single output shaft
16	Inner hex screw	53	Key
17	Input shaft	54	Key
18	Input flange	55	Oil seal
19	2 stage input box cover	56	Inner hex screw
20	Inner hex screw	57	Hole-circlip
21	Key	58	Bearing
22	Gear	59	Hollow shaft
23	Bearing	60	Gear
24	Shim ring	61	Washer
25	3 stage input box cover	62	Bearing
26	Shim ring	63	Shim ring
27	Input shaft	64	Hole-circlip
28	Bearing	65	Oil seal
29	Stifte	66	Key
30	Pinion	67	Washer
31	Pinion shaft	68	Shaft-circlip
32	Bearing	69	Double output shaft
33	Oil sea	70	Housing gasket
34	Shaft-circlip	71	Key
35	Rubber boot	72	Key
36	Closing cap	73	Nameplate
37	Hole-circlip		

SUMMARIZE

Products characteristics

BKM series helical-hypoid gear units is a new generation of product developed by our company. With a compromise of advanced technology both at home and abroad, its main features are as follows.

1. Driven by hypoid gear, has big ratios.
2. Large in output torque, high efficiency, energy saving and nonrusting.
3. Made of high-quality aluminum alloy, light in weight and nonrusting.
4. Smooth in running and low in noise, can work long time in dreadful conditions.
5. Good-looking in appearance, durable in service life and small in volume.
6. Suitable for all round installation, wide application and easy of use.
7. The mounting dimension of BKM series are compatible with NMRW series worm gear unit (A part of NMRV050 dimensions are different from BKM050)
8. Modulaw and multistucture can meet the demands of various conditions.

Main materials

1. Housing : die-cast aluminum alloy (frame size : 050 to 090) ;
grey cast iron (frame size : 110) ;
2. Gear wheel : 20CrMnTi , carbonization & nitrating treatment make the hardness of gear's surface up to 58-62 HRC , retain carburization layer's thickness between 0.3 and 0.6mm after precise grinding.

Surface painting

Aluminum alloy housing :

1. Shot blasting and special antiseptic treatment on the aluminum alloy surface.
2. After phosphating , spray the paint RAL7035 in gray or RAL5010 in blue.

MODEL ILLUMINATE

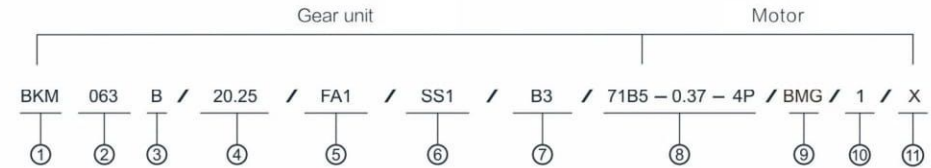

NO	Comments
1	Code for gear units series : BKM
2	Specification code of gear units 050, 063, 075, 090, 110
3	1.B:Means 2 stages 2.C:Means 3 stages
4	Speed ratio of reducer i
5	1.No mark means without output flange 2.FA, FB, FC, FD, FE(1/2);output Flange and position
6	1.No mark means hole output 2.SS(1/2):Single output shaft and position 3.DS:Double output shaft
7	Installation position code
8	1. 71B5:IEC input flange code 2. MV7124: Compact motor type 3. 71B5-0.37-4P: IEC input flange code and model motors (poles of power) 4. 56C: NEMA input flange code 5. ST80 : Servo motor input flange code 6. ST80-80ST-M01330: Servo motor input flange code and servo motor type 7. 80STM-M01330: Compact servo motor type 8. HS:means shaft input
9	1.No mark means without brake 2.BMG:brake
10	Position diagram for motor terminal box default position 1 not to write out is ok
11	Coil position for motor , default position X not to write out is ok

NOTE: When ordering, you should show whether the reducers are equipped with motors, otherwise reducers aren't supplied with motors.

Example: **BKM063C / 63.33 / FA2 / 80B5**

RELEVANT PARAMETER

POWER P

$$P_1 = P_2 / \eta \text{ (kW)}$$

$$P_{1n} \geq P_1 \cdot fs \text{ (kW)}$$

P_1 Input power
 P_{1n} Rated input motor power
 η Transmission efficiency
 P_2 Output power
 fs Service factor

The efficiency of BKM gear units varies with the number of gear stages, between 92% (2-stage), 90% (3-stage).

Rotation speed n

n_1 Gear units input speed
 n_2 Gear units output speed

If driven by the external gearing, 1400r/min or lower rotation speed is suggested so as to optimize the working conditions and prolong the service life. Higher input rotation speed is permitted, but in this situation, the rated torque M2 will be reduced.

Transmission ratio i

$$i = n_1 / n_2 \text{ (kW)}$$

Usually transmission ratio is decimal fraction with 2 radix point tagged in selection tables.

Torque m

$$M_2 = 9550 \cdot P_1 \cdot \eta / n_2 \text{ (Nm)}$$

$$M_{2n} \geq M_2 \cdot fs \text{ (Nm)}$$

M_2 Output torque
 M_{2n} Rated output torque
 P_1 Input power
 η Transmission efficiency
 fs Service factor

RELEVANT PARAMETER

Service factor fs

The effect of the driven machine on the gear unit is taken into account to a sufficient level of accuracy using the service factor fs. The service factor is determined according to the daily operating time and the starting frequency Z.

Three load classifications are considered depending on the mass acceleration factor. You can read off the service factor applicable to your application in following figure. The service factor selected using this diagram must be less than or equal to the service factor as given in the performance parameter table.

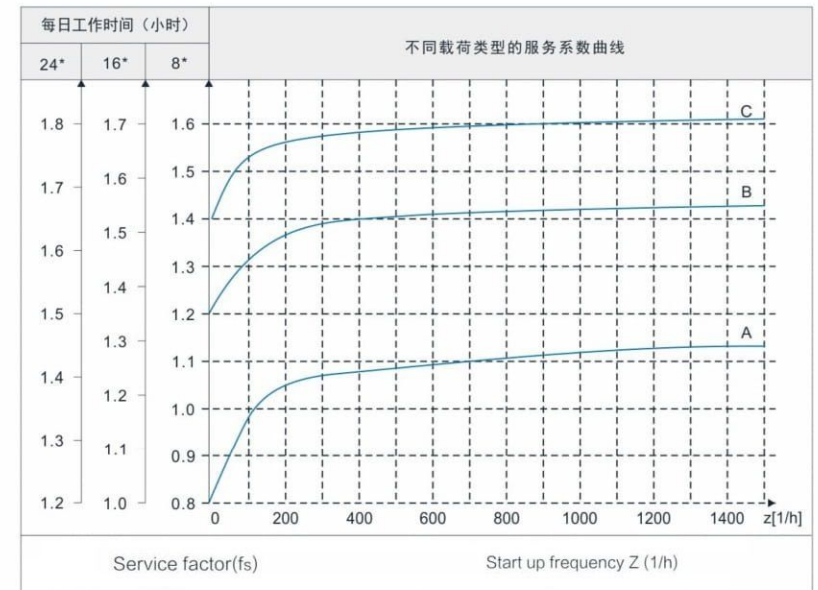

- starting frequency Z: The cycles include all starting and braking procedures as well as change overs from low to high speed.

RELEVANT PARAMETER

Load classifications

Type of load:

- A. Uniform ,permitted mass acceleration factor $F_a \leq 0.2$
- B. Moderate shock load,permitted mass acceleration factor $F_a \leq 3$
- C. Heavy shock load,permitted mass acceleration factor $F_a \leq 10$

Screw feeders for light materials, fans, assembly lines, conveyor belts for light materials, small mixers, lifts, cleaning machines, fillers, control machines.

Winding devices, woodworking machine feeders, goods lifts, balancers, threading machines, medium mixers, conveyor belts for heavy materials, winches, sliding doors, fertilize scrapers, packing machines, concrete mixers, crane mechanisms, milling cutters, folding machines, gear pumps.

Mixers for heavy materials, shears, presses, centrifuges, rotating supports, winches and lifts for heavy materials, grinding lathes, stone mills, bucket elevators, drilling machines, hammer mills, cam presses, folding machines, turntables, tumbling barrels, vibrators, shredders.

Mass acceleration factor

The mass acceleration factor is calculated as follows:

$$F_a = J_c / J_m$$

F_a Mass acceleration factor

J_c All external mass moments of inertia (kgm^2)

J_m Mass moment of inertia on the motor end (kgm^2)

If mass acceleration factors $f_a > 10$, please call our Technical Service.

To keep the service-life of gear units, use factor f_s selected from the catalogue must be equal or slightly higher than the calculated use factor f_s .

Example :

Mass acceleration factor 2.5 (load classification B) , 14hours/day operating time (read off at 16h/d) and 200 cycles/hour result in a service factor $f_s = 1.48$.

choose the service factor $f_s \geq 1.48$ according to the parameter sheet.

RELEVANT PARAMETER

Overhung loads and axial forces

When determining the resulting radial loads, the type of transmission elements, mounted on the shaft end must be considered, various transmission elements are corresponding with following transmission element factors f_z :

Transmission element	Transmission element factor f_z	Comments
Gears	1.15	<17 teeth
Chain sprockets	1.25	<20 teeth
	1.40	<13 teeth
V Narrow V-belt pulleys	1.75	Influence of the tensile force
Flat belt pulleys	2.50	Influence of the tensile force
Toothed belt pulleys	2.50	Influence of the tensile force

The overhung loads exerted on the motor or gear shaft is then calculated as follows.

$$F_r = \frac{M \cdot 2000 \cdot f_z}{d_o} \text{ (N)}$$

F_r Resulting radial load [N]

M Torque on the shafts [Nm]

d_o Mean diameter of the mounted transmission element in [mm] d_o transmission element in [mm]

f_z Transmission element factor

The basis for determining the permitted radial loads is the computation of the rated service life L_{10h} of the bearings (according to ISO281) For special operating conditions , the permitted radial loads can be determined with regard service life L_{na} .

The permitted radial loads given in the selection tables must be calculated using the following formula in the event of force application not in the center of the shaft end. The smaller of the two values $F_x L$ (according to bearing service life)

according to bearing service life :

$$F_x L = F_{r(1,2)} \cdot \frac{a}{b+x} \text{ [N]}$$

$$F_{r1}, F_{r2} = (x=L/2) \text{ [N]}$$

Permitted overhung load ($x=L/2$) for footmounted gear units according to the selection tables in [N]

X = Distance from the shaft shoulder to the force application point in [mm]

a, b = Gear unit constant for overhung load conversion [mm]

RELEVANT PARAMETER

● Output shafts radial loads

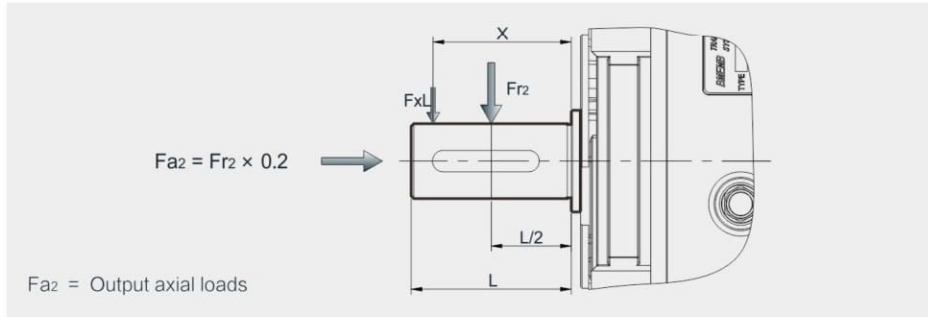

Gear unit constants for overhung load conversion:

	BKM050B	BKM050C	BKM063B	BKM063C	BKM075B	BKM075C	BKM090B	BKM090C	BKM110B	BKM110C
a	104	104	118	118	131	131	159	159	174	174
b	78	78	93	93	101	101	119	119	134	134

● 输入轴径向载荷 / Input shafts radial loads

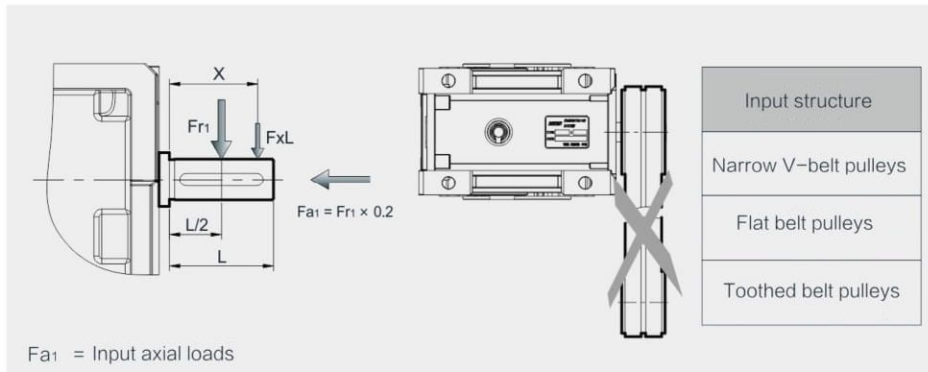

It is forbidden to use the input on the right chart (including 3 stage input) .

Gear unit constants for overhung load conversion:

	BKM050B	BKM050C	BKM063B	BKM063C	BKM075B	BKM075C	BKM090B	BKM090C	BKM110B	BKM110C
a	51.5	56	90	56	73	70	81	70	101	87
b	40	44.5	43	44.5	53	55	61	55	76	67

RELEVANT PARAMETER

Selection tables comments

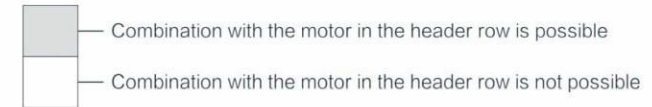

* Finite gear unit reduction ratio

P_{1n} Rated power driving motor [kW]

n_2 Output speed [r/min]

M_{2n} Output torque [Nm]

M_{2max} Max. permissible output torque [Nm]

F_{r2} Permissible overhung load output side [N]

i Gear unit nominal ratio

i_a Gear unit actual ratio

f_s Service factor

Geared motor type

Gear unit type

Motor type

GEAR UNIT SELECTION TABLES

● Selection example

Gear motor

Example : Required power 0.25kW on driven machine , work for 8 h/day , moderate shock load , start up frequency 100 (1/h) , $n_2=35\text{r/min}$, B3 mounted , So :

$$i = \frac{n_1}{n_2} = \frac{1400}{35} = 40$$

Check the service factor table at page 8 , choose $f_s=1.3$

$$P_{in} \geq P_1 \cdot f_s = \frac{P_2}{\eta} \cdot f_s = \frac{0.25}{0.94} \times 1.3 = 0.345 \text{ (kW)}$$

Choose type:

BKM050B / 40.09 / 71B5 / 0.37-4P / B3

Gear units

Example: Required torque 200Nrn on driven machine, work 8 h/day, uniform load, Start up frequency 400(1/h) FA1 mounted, $n_1=900 \text{ r/min}$, $n_2=6 \text{ r/min}$, so the only selection is 3 stage after checked the table:

check the service factor table at page 8, choose $f_s=1$

$$i = \frac{n_1}{n_2} = \frac{900}{6} = 150$$

$$M_{2N} \geq M_2 \cdot f_s = 200 \times 1.05 = 210 \text{ (Nm)}$$

$$P_{in} \geq P_1 \cdot f_s = \frac{M_2 \cdot n_1}{9550 \cdot \eta \cdot i} \cdot f_s = \frac{210 \times 900}{9550 \times 0.92 \times 150} \times 1.05 = 0.151 \text{ (kW)}$$

Choose type:

BKM075C / 151.20 / FA1

GEAR UNIT SELECTION TABLES

BKM 050. ($n_1 = 1400\text{r/min}$)

BKM 050..Possible geometrical combinations ($n_1 = 1400\text{r/min}$)

130Nm

Gear units	i	i	n_2	M_{2max}	F_{r2}	MV63	MV71	MV80	MV90
	Nominal	Actual	[r/min]	[Nm]	[N]				
3 /Stage									
BKM050C	300	291.79	4.8	130	4100				
BKM050C	250	244.29	5.7	130	4100				
BKM050C	200	200.44	7.0	130	4100				
BKM050C	150	146.67	9.5	130	4000				
BKM050C	125	120.34	11.6	130	3770				
BKM050C	100	101.04	13.9	100	3560				
BKM050C	75	74.62	18.8	80	3220				
BKM050C	60	62.36	22	130	3030				
BKM050C	50	52.36	27	100	2860				
2级/Stage									
BKM050B	60	58.36	24	130	2960				
BKM050B	50	48.96	29	130	2790				
BKM050B	40	40.09	35	130	2610				
BKM050B	30	29.33	48	130	2350				
BKM050B	25	24.07	58	130	2200				
BKM050B	20	20.21	69	100	2080				
BKM050B	15	14.92	94	80	1880				
BKM050B	12.5	12.47	112	130	1770				
BKM050B	10	10.47	134	100	1670				
BKM050B	7.5	7.73	181	80	1510				

GEAR UNIT SELECTION TABLES

BKM 063.. $n_1 = 1400\text{r/min}$ **200Nm**
 BKM 063..Possible geometrical combinations ($n_1 = 1400\text{r/min}$)

Gear units	i	i	n_2 [r/min]	$M_{2\max}$ [Nm]	F_{r2} [N]	MV63	MV71	MV80	MV90
	Nominal	Actual							
3/Stage									
BKM063C	300	302.50	4.6	200	4800				
BKM063C	250	243.57	5.7	200	4800				
BKM063C	200	196.43	7.1	180	4800				
BKM063C	150	151.56	9.2	200	4650				
BKM063C	125	122.22	11.5	180	4330				
BKM063C	100	101.27	13.8	150	4070				
BKM063C	75	73.33	19.1	110	3650				
BKM063C	60	63.33	22	180	3480				
BKM063C	50	52.48	27	150	3270				
2/Stage									
BKM063B	60	60.50	23	200	3430				
BKM063B	50	48.71	29	200	3190				
BKM063B	40	39.29	36	180	2970				
BKM063B	30	30.31	46	200	2720				
BKM063B	25	24.44	57	180	2530				
BKM063B	20	20.25	69	150	2380				
BKM063B	15	14.67	95	110	2130				
BKM063B	12.5	12.67	110	180	2030				
BKM063B	10	10.50	133	150	1910				
BKM063B	7.5	7.60	184	110	1710				

GEAR UNIT SELECTION TABLES

BKM 075.. $n_1 = 1400\text{r/min}$ **350Nm**
 BKM 075..Possible geometrical combinations ($n_1 = 1400\text{r/min}$)

Gear units	i	i	n_2 [r/min]	$M_{2\max}$ [Nm]	F_{r2} [N]	MV63	MV71	MV80	MV90	MV100	MV112
	Nominal	Actual									
3/Stage											
BKM075C	300	297.21	4.7	350	6500						
BKM075C	250	240.89	5.8	350	6500						
BKM075C	200	200.66	7.0	300	6500						
BKM075C	150	151.20	9.3	350	6500						
BKM075C	125	125.95	11.1	300	5980						
BKM075C	100	99.22	14.1	240	5520						
BKM075C	75	75.45	18.6	200	5040						
BKM075C	60	62.43	22	300	4730						
BKM075C	50	49.18	28	240	4370						
2/Stage											
BKM075B	60	59.44	24	350	4660						
BKM075B	50	48.18	29	350	4340						
BKM075B	40	40.13	35	300	4080						
BKM075B	30	30.24	46	350	3720						
BKM075B	25	25.19	56	300	3500						
BKM075B	20	19.84	71	240	3230						
BKM075B	15	15.09	93	200	2950						
BKM075B	12.5	12.49	112	300	2770						
BKM075B	10	9.84	142	240	2550						
BKM075B	7.5	7.48	187	200	2330						

GEAR UNIT SELECTION TABLES

BKM 090.. $n_1 = 1400\text{r/min}$ **500Nm**
 BKM 090..Possible geometrical combinations ($n_1 = 1400\text{r/min}$)

Gear units	i	i	n_2 [r/min]	$M_{2\text{max}}$ [Nm]	F_{r2} [N]	MV63	MV71	MV80	MV90	MV100	MV112
	Nominal	Actual									
3/Stage											
BKM090C	300	295.18	4.7	500	8300						
BKM090C	250	240.89	5.8	500	8300						
BKM090C	200	200.66	7.0	480	8300						
BKM090C	150	151.20	9.3	500	8050						
BKM090C	125	125.95	11.1	480	7580						
BKM090C	100	99.22	14.1	380	7000						
BKM090C	75	75.45	18.6	300	6390						
BKM090C	60	62.43	22	480	6000						
BKM090C	50	49.18	28	380	5540						
2/Stage											
BKM090B	60	59.04	24	500	5890						
BKM090B	50	48.18	29	500	5500						
BKM090B	40	40.13	35	480	5170						
BKM090B	30	30.24	46	500	4710						
BKM090B	25	25.19	56	480	4430						
BKM090B	20	19.84	71	380	4090						
BKM090B	15	15.09	93	300	3730						
BKM090B	12.5	12.49	112	480	3510						
BKM090B	10	9.84	142	380	3240						
BKM090B	7.5	7.48	187	300	2950						

GEAR UNIT SELECTION TABLES

BKM 110.. $n_1 = 1400\text{r/min}$ **750Nm**
 BKM 110..Possible geometrical combinations ($n_1 = 1400\text{r/min}$)

Gear units	i	i	n_2 [r/min]	$M_{2\text{max}}$ [Nm]	F_{r2} [N]	MV71	MV80	MV90	MV100	MV112	MV132
	公称 Nominal	实际 Actual									
3/Stage											
BKM110C	300	296.10	4.7	750	10000						
BKM110C	250	244.29	5.7	750	10000						
BKM110C	200	206.29	6.8	750	9920						
BKM110C	150	153.33	9.1	750	8980						
BKM110C	125	129.48	10.8	750	8490						
BKM110C	100	103.64	13.5	650	7880						
BKM110C	75	75.55	18.5	520	7090						
BKM110C	60	64.18	22	750	6720						
BKM110C	50	51.37	27	650	6240						
2/Stage											
BKM110B	60	59.22	24	750	6540						
BKM110B	50	48.86	29	750	6130						
BKM110B	40	41.26	34	750	5800						
BKM110B	30	30.67	46	750	5250						
BKM110B	25	25.90	54	750	4960						
BKM110B	20	20.73	68	650	4610						
BKM110B	15	15.11	93	520	4150						
BKM110B	12.5	12.84	109	750	3930						
BKM110B	10	10.27	136	650	3650						
BKM110B	7.5	7.49	187	520	3280						



GEAR UNIT SELECTION TABLES

BKM+ST Servo gear unit possible geometrical combinations($n_1=1500r/min$)

BKM	ST	7.5	10	12.5	15	20	25	30	40	50	60	75	100	125	150	200	250	300	
050	100W																		
	200W	●	●	●															
	400W																		
	500W																		
	750W																		
	1000W																		
	1500W																		
063	200W	●	●	●	●	●	●	●											
	400W	●	●	●															
	500W																		
	750W																		
	1000W																		
	1500W																		
075	400W	●	●	●	●	●	●	●											
	500W	●	●	●															
	750W	●	●	●															
	1000W																		
	1500W																		
	2000W																		
	3000W																		
4000W																			
090	400W	●	●	●	●	●	●	●											
	500W	●	●	●	●	●	●												
	750W	●	●	●															
	1000W	●	●	●															
	1500W																		
	2000W																		
	3000W																		
	4000W																		
110	750W	●	●	●	●	●	●	●											
	1000W	●	●	●	●														
	1500W	●	●	●															
	2000W																		
	3000W																		
	4000W																		
5000W																			

GEAR UNIT SELECTION TABLES

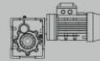
BKM.. Performance parameter

P_{in} [kW]	n_2 [r/min]	M_{2max} [Nm]	i Nominal	i Actual	F_2 [N]	f_s			
0.12	4.8	215	300	291.79	4100	0.6	BKM050C MV6314	BKM050C 63B5	6314
	5.7	180	250	244.29	4100	0.72			
	7.0	148	200	200.44	4100	0.88			
	9.5	108	150	146.67	4000	1.2			
	11.6	89	125	120.34	3770	1.5			
	13.9	74	100	101.04	3560	1.3			
	18.8	55	75	74.62	3220	1.5			
	22	46	60	62.36	3030	2.8			
	27	39	50	52.36	2860	2.6			
	24	44	60	58.36	2960	3.0	BKM050B MV6314	BKM050B 63B5	6314
	29	37	50	48.86	2790	3.5			
	35	30	40	40.09	2610	4.3			
	48	22	30	29.33	2350	5.9			
	58	18.1	25	24.07	2200	7.2			
	69	15.2	20	20.21	2080	6.6			
	94	11.2	15	14.92	1880	7.1			
	112	9.4	12.5	12.47	1770	13.8			
	134	7.9	10	10.47	1670	12.7			
	181	5.8	7.5	7.73	1510	13.7			
	4.6	223	300	302.50	4800	0.9	BKM063C MV6314	BKM063C 63B5	6314
5.7	179	250	243.57	4800	1.1				
7.1	145	200	196.43	4800	1.2				
9.2	112	150	151.56	4650	1.8				
11.5	90	125	122.22	4330	2.0				
13.8	75	100	101.27	4070	2.0				
19.1	54	75	73.33	3650	2.0				
22	47	60	63.33	3480	3.9				
27	39	50	52.48	3270	3.9				
23	46	60	60.50	3420	4.4	BKM063B MV6314	BKM063B 63B5	6314	
29	37	50	48.71	3190	5.5				
36	30	40	39.29	2970	6.1				
46	23	30	30.31	2720	8.8				
4.7	219	300	297.21	6500	1.6	BKM075C MV6314	BKM075C 63B5	6314	
5.8	177	250	240.89	6500	2.0				
7.0	148	200	200.66	6500	2.0				
9.3	111	150	151.20	6500	3.1				
11.1	93	125	125.95	5980	3.2				
14.1	73	100	99.22	5520	3.3				
18.6	56	75	75.45	5040	3.6				

PERFORMANCE PARAMETER

P _{1n} [kW]	n ₂ [r/min]	M _{2max} [Nm]	i		F ₂ [N]	fs					
			Nominal	Actual							
0.12	4.7	217	300	295.18	8300	2.3	BKM090C	MV6314	BKM090C	63B5	6314
	5.8	177	250	240.89	8300	2.8					
	7.0	148	200	200.66	8300	3.2					
	9.3	111	150	151.20	8050	4.5					
0.18	9.6	161	300	291.79	4000	0.81	BKM050C	MV6312	BKM050C	63B5	6312
	11.5	135	250	244.29	3790	0.96					
	14.0	111	200	200.44	3550	1.2					
	19.1	81	150	146.67	3200	1.6					
	23	66	125	120.34	2990	2.0					
	28	56	100	101.04	2820	1.8					
	38	41	75	74.62	2550	1.9					
	45	34	60	62.36	2400	3.8					
	53	29	50	52.36	2270	3.5	BKM050C	MV6324	BKM050C	63B5	6324
	11.6	133	125	120.34	3770	0.98					
	13.9	112	100	101.04	3560	0.9					
	18.8	82	75	74.62	3220	0.97					
	22	69	60	62.36	3030	1.9	BKM050B	MV6324	BKM050B	63B5	6324
	27	58	50	52.36	2860	1.7					
	24	66	60	58.36	2960	2.0					
	29	55	50	48.86	2790	2.4					
35	45	40	40.09	2610	2.9						
48	33	30	29.33	2350	3.9						
58	27	25	24.07	2200	4.8	BKM050C	MV7116	BKM050C	71B5/B14	7116	
69	23	20	20.21	2080	4.4						
94	17.2	15	14.92	1880	4.7	BKM050B	MV7116	BKM050B	71B5/B14	7116	
14.4	107	60	62.36	3510	1.2						
17.2	90	50	52.36	3310	1.1						
15.4	103	60	58.36	3430	1.3						
18.4	86	50	48.86	3240	1.5						
22	70	40	40.09	3030	1.8						
31	52	30	29.33	2730	2.5						
37	42	25	24.07	2550	3.1						
45	36	20	20.21	2410	2.8						
60	26	15	14.92	2180	3.1						
72	22	12.5	12.47	2050	5.9	BKM063C	MV6312	BKM063C	63B5	6312	
86	18.4	10	10.47	1930	5.4						
116	13.6	7.5	7.73	1750	5.9						
9.3	167	300	302.50	4650	1.2						
11.5	135	250	243.57	4330	1.5	BKM063C	MV6312	BKM063C	63B5	6312	
14.3	109	200	196.43	4030	1.7						
18.5	84	150	151.56	3690	2.4						
23	68	125	122.22	3440	2.7						

PERFORMANCE PARAMETER

P _{1n} [kW]	n ₂ [r/min]	M _{2max} [Nm]	i		F ₂ [N]	fs					
			Nominal	Actual							
0.12	28	56	100	101.27	3230	2.7	BKM063C	MV6312	BKM063C	63B5	6312
	38	41	75	73.33	2900	2.7					
	44	35	60	63.33	2760	5.1					
	53	29	50	52.48	2590	5.2					
	7.1	217	200	196.43	4800	0.83					
	9.2	167	150	151.56	4650	1.2					
	11.5	135	125	122.22	4330	1.3					
	13.8	112	100	101.27	4070	1.3					
	19.1	81	75	73.33	3650	1.4					
	22	70	60	63.33	3480	2.6					
27	58	50	52.48	3270	2.6	BKM063B	MV6324	BKM063B	63B5	6324	
23	68	60	60.50	3430	2.9						
29	55	50	48.71	3190	3.6						
36	44	40	39.29	2970	4.1	BKM063C	MV7116	BKM063C	71B5/B14	7116	
7.4	210	125	122.22	4800	0.86						
8.9	174	100	101.27	4720	0.86						
12.3	126	75	73.33	4230	0.87						
14.2	109	60	63.33	4030	1.7						
17.1	90	50	52.48	3790	1.7	BKM063B	MV7116	BKM063B	71B5/B14	7116	
14.9	106	60	60.50	3970	1.9						
18.5	86	50	48.71	3690	2.3						
23	69	40	39.29	3440	2.6						
30	53	30	30.31	3150	3.8						
37	43	25	24.44	2930	4.2						
44	36	20	20.25	2760	4.2	BKM075C	MV6312	BKM075C	63B5	6312	
61	26	15	14.67	2470	4.3						
9.4	164	300	297.21	6320	2.1						
11.6	133	250	240.89	5890	2.6						
14.0	111	200	200.66	5540	2.7	BKM075C	MV6324	BKM075C	63B5	6324	
18.5	84	150	151.20	5040	4.2						
4.7	328	300	297.21	6500	1.1						
5.8	266	250	240.89	6500	1.3						
7.0	222	200	200.66	6500	1.4						
9.3	167	150	151.20	6500	2.1	BKM075C	MV7116	BKM075C	71B5/B14	7116	
11.1	139	125	125.95	5980	2.2						
14.1	110	100	99.22	5520	2.2						
18.6	83	75	75.45	5040	2.4						
3.7	414	250	240.89	6500	0.85	BKM075C	MV7116	BKM075C	71B5/B14	7116	
4.5	345	200	200.66	6500	0.87						
6.0	260	150	151.20	6500	1.3						

PERFORMANCE PARAMETER

	P_{in} [kW]	n_2 [r/min]	M_{2max} [Nm]	i		F_{r2} [N]	f_s				
				Nominal	Actual						
0.18	7.1	217	125	125.95	6500	1.4	BKM075C	MV7116	BKM075C	71B5/B14	7116
	9.1	171	100	99.22	6400	1.4					
	11.9	130	75	75.45	5840	1.5					
	14.4	107	60	62.43	5480	2.8					
	18.3	85	50	49.18	5060	2.8					
	15.1	107	60	59.44	5390	3.4					
	18.7	85	50	48.18	5030	4.1	BKM075B	MV7116	BKM075B	71B5/B14	7116
	22	71	40	40.13	4730	4.3					
	9.5	163	300	295.18	7990	3.1	BKM090C	MV6312	BKM090C	63B5	6312
	11.6	133	250	240.89	7470	3.8					
	14.0	111	200	200.66	7030	4.3					
	4.7	326	300	295.18	8300	1.5	BKM090C	MV6324	BKM090C	63B5	6324
	5.8	266	250	240.89	8300	1.9					
	7.0	222	200	200.66	8300	2.2					
	9.3	167	150	151.20	8050	3.0					
	11.1	139	125	125.95	7580	3.4					
	14.1	110	100	99.22	7000	3.5					
	18.6	83	75	75.45	6390	3.6					
3.0	507	300	295.18	8300	1.0	BKM090C					
3.7	414	250	240.89	8300	1.2						
4.5	345	200	200.66	8300	1.4						
6.0	260	150	151.20	8300	1.9						
7.1	217	125	125.95	8300	2.2						
9.1	171	100	99.22	8110	2.2						
11.9	130	75	75.45	7400	2.3						
14.4	107	60	62.43	6950	4.5						
18.3	85	50	49.18	6420	4.5						
3.0	520	300	296.10	10000	1.5	BKM110C	MV7116	BKM110C	71B5/B14	7116	
3.7	420	250	244.29	10000	1.8						
4.4	355	200	206.29	10000	2.1						
5.9	264	150	153.33	10000	2.8						
7.0	223	125	129.48	9840	3.4						
8.7	178	100	103.64	9130	3.6						
11.9	130	75	75.55	8220	4.0	0.25	BKM050C	MV6322	BKM050C	63B5	6322
19.1	113	150	146.67	3200	1.2						
23	92	125	120.34	2990	1.4						
28	78	100	101.04	2820	1.3						
38	57	75	74.62	2550	1.4						
45	48	60	62.36	2400	2.7						
53	40	50	52.36	2270	2.5						

PERFORMANCE PARAMETER

	P_{in} [kW]	n_2 [r/min]	M_{2max} [Nm]	i		F_{r2} [N]	f_s								
				Nominal	Actual										
0.25	22	96	60	62.36	3030	1.4	BKM050C	MV6334	BKM050C	71B5/B14	7114				
	27	80	50	52.36	2860	1.2									
	24	92	60	58.36	2960	1.4	BKM050B	MV6334	BKM050B	71B5/B14	7114				
	29	77	50	48.86	2790	1.7									
	35	63	40	40.09	2610	2.1									
	48	46	30	29.33	2350	2.8									
	58	38	25	24.07	2200	3.4									
	69	32	20	20.21	2080	3.2									
	94	23	15	14.92	1880	3.4									
	15.4	142	60	58.36	3430	0.9						BKM050B	MV7126	BKM050B	71B5/B14
	18.4	119	50	48.86	3240	1.1									
	22	98	40	40.09	3030	1.3									
	31	72	30	29.33	2730	1.8									
	37	59	25	24.07	2550	2.2									
	45	49	20	20.21	2410	2.0									
	60	36	15	14.92	2180	2.2									
	72	30	12.5	12.47	2050	4.3									
	86	26	10	10.47	1930	3.9									
116	19	7.5	7.73	1750	4.2										
9.3	232	300	302.50	4650	0.86	BKM063C	MV6322	BKM063C	63B5	6322					
11.5	187	250	243.57	4330	1.1										
14.3	151	200	196.43	4030	1.2										
18.5	116	150	151.56	3690	1.7										
23	94	125	122.22	3440	1.9										
28	78	100	101.27	3230	1.9										
38	56	75	73.33	2900	2.0										
44	49	60	63.33	2760	3.7										
53	40	50	52.48	2590	3.7										
9.2	233	150	151.56	4650	0.86						BKM063C	MV6334	BKM063C	71B5/B14	7114
11.5	188	125	122.22	4330	0.96										
13.8	155	100	101.27	4070	0.97										
19.1	113	75	73.33	3650	1.0										
22	97	60	63.33	3480	1.9										
27	81	50	52.48	3270	1.9										
23	95	60	60.50	3430	2.1	BKM063B	MV6334	BKM063B	71B5/B14	7114					
29	76	50	48.71	3190	2.6										
36	62	40	39.29	2970	2.9										
46	48	30	30.31	2720	4.2										
14.2	151	60	63.33	4030	1.2	BKM063C	MV7126	BKM063C	71B5/B14	7126					
17.1	125	50	52.48	3790	1.2										



PERFORMANCE PARAMETER

	P_{in} [kW]	n_2 [r/min]	M_{2max} [Nm]	i		F_{r2} [N]	f_s				
				Nominal	Actual						
0.25	14.9	148	60	60.50	3970	1.4	BKM063B	MV7126	BKM063B	71B5/B14	7126
	18.5	119	50	48.71	3690	1.7					
	23	96	40	39.29	3440	1.9					
	30	74	30	30.31	3150	2.7					
	37	60	25	24.44	2930	3.0					
	44	49	20	20.25	2760	3.0					
	61	36	15	14.67	2470	3.1					
	9.4	228	300	297.21	6320	1.5	BKM075C	MV6322	BKM075C	63B5	6322
	11.6	185	250	240.89	5890	1.9					
	14.0	154	200	200.66	5540	1.9					
	18.5	116	150	151.20	5040	3.0					
	22	97	125	125.95	4750	3.1					
	28	76	100	99.22	4380	3.2					
	37	58	75	75.45	4000	3.5					
	5.8	370	250	240.89	6500	0.95	BKM075C	MV6334	BKM075C	71B5/B14	7114
	7.0	308	200	200.66	6500	1.0					
	9.3	232	150	151.20	6500	1.5					
	11.1	193	125	125.95	5980	1.6					
	14.1	152	100	99.22	5520	1.6					
	18.6	116	75	75.45	5040	1.7					
	22	96	60	62.43	4730	3.1					
	28	75	50	49.18	4370	3.2					
	24	93	60	59.44	4660	3.8	BKM075B	MV6334	BKM075B	71B5/B14	7114
	29	76	50	48.18	4340	4.6					
	6.0	361	150	151.20	6500	0.97	BKM075C	MV7126	BKM075C	71B5/B14	7126
	7.1	301	125	125.95	6500	1.0					
	9.1	237	100	99.22	6400	1.0					
	11.9	180	75	75.45	5840	1.1					
14.4	149	60	62.43	5480	2.0						
18.3	117	50	49.18	5060	2.0						
15.1	145	60	59.44	5390	2.4						
18.7	118	50	48.18	5030	3.0	BKM075B	MV7126	BKM075B	71B5/B14	7126	
22	98	40	40.13	4730	3.1						
9.5	227	300	295.18	7990	2.2						
11.6	185	250	240.89	7470	2.7	BKM090C	MV6322	BKM090C	63B5	6322	
14.0	154	200	200.66	7030	3.1						
18.5	116	150	151.20	6390	4.3						
4.7	453	300	295.18	8300	1.1	BKM090C	MV6334	BKM090C	71B5/B14	7114	
5.8	370	250	240.89	8300	1.4						
7.0	308	200	200.66	8300	1.6						



PERFORMANCE PARAMETER

	P_{in} [kW]	n_2 [r/min]	M_{2max} [Nm]	i		F_{r2} [N]	f_s								
				Nominal	Actual										
0.25	9.3	232	150	151.20	8050	2.2	BKM090C	MV6334	BKM090C	71B5/B14	7114				
	11.1	193	125	125.95	7580	2.5									
	14.1	152	100	99.22	7000	2.5									
	18.6	116	75	75.45	6390	2.6									
	22	96	60	62.43	6000	5.0									
	28	75	50	49.18	5540	5.0									
	3.0	705	300	295.18	8300	0.71						BKM090C	MV7126	BKM090C	71B5/B14
	3.7	575	250	240.89	8300	0.9									
	4.5	479	200	200.66	8300	1.0									
	6.0	361	150	151.20	8300	1.4									
	7.1	301	125	125.95	8300	1.6									
	9.1	237	100	99.22	8110	1.6									
	11.9	180	75	75.45	7400	1.7									
	14.4	149	60	62.43	6950	3.2	BKM090B	MV7126	BKM090B	71B5/B14	7126				
	18.3	117	50	49.18	6420	3.2									
	15.2	144	60	59.04	6820	3.5									
	18.7	118	50	48.18	6370	4.3	BKM110C	MV6334	BKM110C	71B5/B14	7114				
	4.7	454	300	296.10	10000	1.7									
	5.7	375	250	244.29	10000	2.0									
	6.8	317	200	206.29	9920	2.4									
	9.1	235	150	153.33	8980	3.2									
	10.8	199	125	129.48	8490	3.8									
	13.5	159	100	103.64	7880	4.1									
	3.0	707	300	296.10	10000	1.1	BKM110C	MV7126	BKM110C	71B5/B14	7126				
	3.7	583	250	244.29	10000	1.3									
	4.4	493	200	206.29	10000	1.5									
	5.9	366	150	153.33	10000	2.0									
	7.0	309	125	129.48	9840	2.4									
8.7	247	100	103.64	9130	2.6										
11.9	180	75	75.55	8220	2.9										
23	137	125	120.34	2990	0.95	BKM050C	MV6332	BKM050C	71B5/B14	7112					
28	115	100	101.04	2820	0.87										
38	85	75	74.62	2550	0.94										
45	71	60	62.36	2400	1.8										
53	59	50	52.36	2270	1.7										
24	136	60	58.36	2960	0.96						BKM050B	MV7124	BKM050B	71B5/B14	7124
29	113	50	48.86	2790	1.1										
35	93	40	40.09	2610	1.4										
48	68	30	29.33	2350	1.9										
58	56	25	24.07	2200	2.3										



PERFORMANCE PARAMETER

P _{in} [kW]	n ₂ [r/min]	M _{2max} [Nm]	i		F _{r2} [N]	fs	  				
			Nominal	Actual							
0.37	69	47	20	20.21	2080	2.1	BKM050B	MV7124	BKM050B	71B5/B14	7124
	94	35	15	14.92	1880	2.3					
	112	29	12.5	12.47	1770	4.5					
	134	24	10	10.47	1670	4.1					
	181	17.9	7.5	7.73	1510	4.5					
	22	145	40	40.09	3030	0.9	BKM050B	MV8016	BKM050B	80B5/B14	8016
	31	106	30	29.33	2730	1.2					
	37	87	25	24.07	2550	1.5					
	45	73	20	20.21	2410	1.4					
	60	54	15	14.92	2180	1.5					
	72	45	12.5	12.47	2050	2.9					
	86	38	10	10.47	1930	2.6	BKM063C	MV6332	BKM063C	71B5/B14	7112
	116	28	7.5	7.73	1750	2.9					
	18.5	172	150	151.56	3690	1.2					
	23	139	125	122.22	3440	1.3					
	28	115	100	101.27	3230	1.3					
	38	83	75	73.33	2900	1.3	BKM063C	MV7124	BKM063C	71B5/B14	7124
	44	72	60	63.33	2760	2.5					
53	60	50	52.48	2590	2.5						
22	144	60	63.33	3480	1.3						
27	119	50	52.48	3270	1.3						
23	140	60	60.50	3430	1.4	BKM063B	MV7124	BKM063B	71B5/B14	7124	
29	113	50	48.71	3190	1.8						
36	91	40	39.29	2970	2.0						
46	70	30	30.31	2720	2.8						
57	57	25	24.44	2530	3.2						
69	47	20	20.25	2380	3.2						
95	34	15	14.67	2130	3.2	BKM063B	MV8016	BKM063B	80B5/B14	8016	
14.9	219	60	60.50	3970	0.92						
18.5	176	50	48.71	3690	1.1						
23	142	40	39.29	3440	1.3						
30	109	30	30.31	3150	1.8						
37	88	25	24.44	2930	2.0						
44	73	20	20.25	2760	2.1						
61	53	15	14.67	2470	2.1						
71	46	12.5	12.67	2360	3.9						
86	38	10	10.50	2210	4.0						
118	27	7.5	7.60	1990	4.0	BKM075C	MV6332	BKM075C	71B5/B14	7112	
9.4	338	300	297.21	6320	1.0						
11.6	274	250	240.89	5890	1.3						

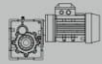
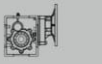

PERFORMANCE PARAMETER

P _{in} [kW]	n ₂ [r/min]	M _{2max} [Nm]	i		F _{r2} [N]	fs	  				
			Nominal	Actual							
0.37	14.0	228	200	200.66	5540	1.3	BKM075C	MV6332	BKM075C	71B5/B14	7112
	18.5	172	150	151.20	5040	2.0					
	22	143	125	125.95	4750	2.1					
	28	113	100	99.22	4380	2.1					
	37	86	75	75.45	4000	2.3					
	45	71	60	62.43	3750	4.2					
	57	56	50	49.18	3470	4.3	BKM075C	MV7124	BKM075C	71B5/B14	7124
	9.3	343	150	151.20	6500	1.0					
	11.1	286	125	125.95	5980	1.0					
	14.1	225	100	99.22	5520	1.1					
	18.6	171	75	75.45	5040	1.2					
	22	142	60	62.43	4730	2.1					
	28	112	50	49.18	4370	2.1	BKM075B	MV7124	BKM075B	71B5/B14	7124
	24	138	60	59.44	4660	2.5					
	29	112	50	48.18	4340	3.1					
	35	93	40	40.13	4080	3.2	BKM075C	MV8016	BKM075C	80B5/B14	8016
	14.4	221	60	62.43	5480	1.4					
	18.3	174	50	49.18	5060	1.4					
	15.1	215	60	59.44	5390	1.6					
	18.7	174	50	48.18	5030	2.0					
	22	145	40	40.13	4730	2.1					
	30	109	30	30.24	4310	3.2	BKM075B	MV8016	BKM075B	80B5/B14	8016
	36	91	25	25.19	4050	3.3					
	45	72	20	19.84	3740	3.3					
60	55	15	15.09	3410	3.7						
9.5	335	300	295.18	7990	1.5						
11.6	274	250	240.89	7470	1.8						
14.0	228	200	200.66	7030	2.1	BKM090C	MV6332	BKM090C	71B5/B14	7112	
18.5	172	150	151.20	6390	2.9						
22	143	125	125.95	6010	3.4						
28	113	100	99.22	5550	3.4						
37	86	75	75.45	5070	3.5						
4.7	671	300	295.18	8300	0.75						BKM090C
5.8	547	250	240.89	8300	0.91						
7.0	456	200	200.66	8300	1.1						
9.3	343	150	151.20	8050	1.5						
11.1	286	125	125.95	7580	1.7						
14.1	225	100	99.22	7000	1.7						
18.6	171	75	75.45	6390	1.8						
22	142	60	62.43	6000	3.4						

PERFORMANCE PARAMETER

	P_{in} [kW]	n_2 [r/min]	M_{2max} [Nm]	i		F_{r2} [N]	fs	  			
				Nominal	Actual			BKM090C	MV7124	BKM090C	71B5/B14
0.37	28	112	50	49.18	5540	3.4	BKM090C	MV7124	BKM090C	71B5/B14	7124
	24	137	60	59.04	5890	3.6	BKM090B	MV7124	BKM090B	71B5/B14	7124
	29	112	50	48.18	5500	4.5					
	6.0	534	150	151.20	8300	0.94					
	7.1	445	125	125.95	8300	1.1					
	9.1	351	100	99.22	8110	1.1	BKM090C	MV8016	BKM090C	80B5/B14	8016
	11.9	267	75	75.45	7400	1.1					
	14.4	221	60	62.43	6950	2.2					
	18.3	174	50	49.18	6420	2.2					
	15.2	213	60	59.04	6820	2.3					
	18.7	174	50	48.18	6370	2.9	BKM090B	MV8016	BKM090B	80B5/B14	8016
	22	145	40	40.13	6000	3.3					
	9.5	336	300	296.10	8880	2.2					
	11.5	277	250	244.29	8330	2.7	BKM110C	MV6332	BKM110C	71B5/B14	7112
	13.6	234	200	206.29	7870	3.2					
	18.3	174	150	153.33	7130	4.3					
	4.7	673	300	296.10	10000	1.1					
	5.7	555	250	244.29	10000	1.4					
	6.8	469	200	206.29	9920	1.6					
	9.1	348	150	153.33	8980	2.2	BKM110C	MV7124	BKM110C	71B5/B14	7124
	10.8	294	125	129.48	8490	2.5					
	13.5	235	100	103.64	7880	2.8					
	18.5	172	75	75.55	7090	3.0					
	4.4	729	200	206.29	10000	1.0					
5.9	542	150	153.33	10000	1.4						
7.0	458	125	129.48	9840	1.6						
8.7	366	100	103.64	9130	1.8	BKM110C	MV8016	BKM110C	80B5/B14	8016	
11.9	267	75	75.55	8220	1.9						
14.0	227	60	64.18	7780	3.3						
17.5	182	50	51.37	7230	3.6						
15.2	214	60	59.22	7580	3.5	BKM110B	MV8016	BKM110B	80B5/B14	8016	
18.4	176	50	48.86	7110	4.2						
0.55	45	105	60	62.36	2400	1.2	BKM050C	MV7122	BKM050C	71B5/B14	7122
	53	88	50	52.36	2270	1.1					
	35	138	40	40.09	2610	0.94					
	48	101	30	29.33	2350	1.3					
	58	83	25	24.07	2200	1.6	BKM050B	MV8014	BKM050B	80B5/B14	8014
	69	70	20	20.21	2080	1.4					
	94	51	15	14.92	1880	1.6					
	112	43	12.5	12.47	1770	3.0					

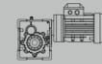
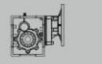
PERFORMANCE PARAMETER

	P_{in} [kW]	n_2 [r/min]	M_{2max} [Nm]	i		F_{r2} [N]	fs	  			
				Nominal	Actual			BKM050B	MV8014	BKM050B	80B5/B14
0.55	134	36	10	10.47	1670	2.8	BKM050B	MV8014	BKM050B	80B5/B14	8014
	181	27	7.5	7.73	1510	3.0					
	37	129	25	24.07	2550	1.0					
	45	109	20	20.21	2410	0.92					
	60	80	15	14.92	2180	1.0	BKM050B	MV8026	BKM050B	80B5/B14	8026
	72	67	12.5	12.47	2050	1.9					
	86	56	10	10.47	1930	1.8					
	116	42	7.5	7.73	1750	1.9					
	23	206	125	122.22	3440	0.87					
	28	171	100	101.27	3230	0.88					
	38	124	75	73.33	2900	0.9	BKM063C	MV7122	BKM063C	71B5/B14	7122
	44	107	60	63.33	2760	1.7					
	53	89	50	52.48	2590	1.7					
	23	209	60	60.50	3430	0.96					
	29	168	50	48.71	3190	1.2					
	36	136	40	39.29	2970	1.3					
	46	105	30	30.31	2720	1.9					
	57	84	25	24.44	2530	2.1	BKM063B	MV8014	BKM063B	80B5/B14	8014
	69	70	20	20.25	2380	2.1					
	95	51	15	14.67	2130	2.2					
	110	44	12.5	12.67	2030	4.1					
	133	36	10	10.50	1910	4.1					
	184	26	7.5	7.60	1710	4.2					
	23	216	40	39.29	3440	0.85					
30	163	30	30.31	3150	1.2						
37	131	25	24.44	2930	1.4						
44	109	20	20.25	2760	1.4	BKM063B	MV8026	BKM063B	80B5/B14	8026	
61	79	15	14.67	2470	4.4						
71	68	12.54	12.67	2360	2.6						
86	56	10	10.50	2210	2.7						
118	41	7.5	7.60	1990	2.7						
11.6	407	250	240.89	5890	0.86						
14.0	339	200	200.66	5540	0.9						
18.5	255	150	151.20	5040	1.4						
22	213	125	125.95	4750	1.4	BKM075C	MV7122	BKM075C	71B5/B14	7122	
28	168	100	99.22	4380	1.4						
37	127	75	75.45	4000	1.6						
45	105	60	62.43	3750	2.8						
57	83	50	49.18	3470	2.9						
18.6	255	75	75.45	5040	0.8	BKM075C	MV8014	BKM075C	80B5/B14	8014	

PERFORMANCE PARAMETER

	P_{in} [kW]	n_2 [r/min]	M_{2max} [Nm]	i		F_{r2} [N]	f_s								
				Nominal	Actual										
0.55	22	211	60	62.43	4730	1.4	BKM075C	MV8014	BKM075C	80B5/B14	8014				
	28	166	50	49.18	4370	1.4									
	24	205	60	59.44	4660	1.7	BKM075B	MV8014	BKM075B	80B5/B14	8014				
	29	166	50	48.18	4340	2.1									
	35	139	40	40.13	4080	2.2									
	46	104	30	30.24	3720	3.4									
	56	87	25	25.19	3500	3.5									
	71	68	20	19.84	3230	3.5									
	93	52	15	15.09	2950	3.8									
	14.4	328	60	62.43	5480	0.91	BKM075C	MV8026	BKM075C	80B5/B14	8026				
	18.3	258	50	49.18	5060	0.93									
	15.1	319	60	59.44	5390	1.1	BKM075B	MV8026	BKM075B	80B5/B14	8026				
	18.7	259	50	48.18	5030	1.4									
	22	215	40	40.13	4730	1.4									
	30	162	30	30.24	4310	2.2									
	36	135	25	25.19	4050	2.2									
	45	107	20	19.84	3740	2.3									
	60	81	15	15.09	3410	2.5									
	9.5	498	300	295.18	7990	1.0	BKM090C	MV7122	BKM090C	71B5/B14	7122				
	11.6	407	250	240.89	7470	1.2									
14.0	339	200	200.66	7030	1.4										
18.5	255	150	151.20	6390	2.0										
22	213	125	125.95	6010	2.3										
28	168	100	99.22	5550	2.3										
37	127	75	75.45	5070	2.4										
45	105	60	62.43	4760	4.6										
57	83	50	49.18	4390	4.6										
9.3	511	150	151.20	8050	1.0	BKM090C						MV8014	BKM090C	80B5/B14	8014
11.1	425	125	125.95	7580	1.1										
14.1	335	100	99.22	7000	1.1										
18.6	255	75	75.45	6390	1.2										
22	211	60	62.43	6000	2.3										
28	166	50	49.18	5540	2.3										
24	204	60	59.04	5890	2.5		BKM090B	MV8014	BKM090B	80B5/B14	8014				
29	166	50	48.18	5500	3.0										
35	139	40	40.13	5170	3.5										
46	104	30	30.24	4710	4.8										
14.4	328	60	62.43	6950	1.5	BKM090C	MV8026	BKM090C	80B5/B14	8026					
18.3	258	50	49.18	6420	1.5										
15.2	317	60	59.04	6820	1.6	BKM090B	MV8026	BKM090B	80B5/B14	8026					

PERFORMANCE PARAMETER

	P_{in} [kW]	n_2 [r/min]	M_{2max} [Nm]	i		F_{r2} [N]	f_s					
				Nominal	Actual							
0.55	18.7	259	50	48.18	6370	1.9	BKM090B	MV8026	BKM090B	80B5/B14	8026	
	22	215	40	40.13	6000	2.2						
	30	162	30	30.24	5460	3.1						
	36	135	25	25.19	5130	3.5						
	45	107	20	19.84	4740	3.6						
	60	81	15	15.09	4330	3.7						
	9.5	500	300	296.10	8880	1.5						BKM110C
	11.5	412	250	244.29	8330	1.8						
	13.6	348	200	206.29	7870	2.2						
	18.3	259	150	153.33	7130	2.9						
	22	219	125	129.48	6740	3.4						
	27	175	100	103.64	6260	3.7						
	37	128	75	75.55	5630	4.1						
	5.7	825	250	244.29	10000	0.91	BKM110C	MV8014	BKM110C	80B5/B14	8014	
	6.8	697	200	206.29	9920	1.1						
	9.1	518	150	153.33	8980	1.4						
	10.8	437	125	129.48	8490	1.7						
	13.5	350	100	103.64	7880	1.9						
	18.5	255	75	75.55	7090	2.0						
	22	217	60	64.18	6720	3.5						
27	173	50	51.37	6240	3.7							
24	204	60	59.22	6540	3.7	BKM110B	MV8014	BKM110B	80B5/B14	8014		
29	169	50	48.86	6130	4.4							
5.9	805	150	153.33	10000	0.93	BKM110C	MV8026	BKM110C	80B5/B14	8026		
7.0	680	125	129.48	9840	1.1							
8.7	544	100	103.64	9130	1.2							
11.9	397	75	75.55	8220	1.3							
14.0	337	60	64.18	7780	2.2							
17.5	270	50	51.37	7230	2.4							
15.2	318	60	59.22	7580	2.4						BKM110B	MV8026
18.4	262	50	48.86	7110	2.9							
22	222	40	41.26	6720	3.4							
29	165	30	30.67	6090	4.6							
48	138	30	29.33	2350	0.94	BKM050B	MV8024	BKM050B	80B5/B14	8024		
58	113	25	24.07	2200	1.1							
69	95	20	20.21	2080	1.1							
94	70	15	14.92	1880	1.1							
112	59	12.5	12.47	1770	2.2							
134	49	10	10.47	1670	2.0							
181	36	7.5	7.73	1510	2.2							



PERFORMANCE PARAMETER

	P_{in} [kW]	n_2 [r/min]	M_{2max} [Nm]	i		F_{r2} [N]	f_s									
				Nominal	Actual											
0.75	72	91	12.5	12.47	2050	1.4	BKM050B	MV90S6	BKM050B	90B5/B14	90S6					
	86	77	10	10.47	1930	1.3										
	116	57	7.5	7.73	1750	1.4										
	44	146	60	63.33	2760	1.2	BKM063C	MV8012	BKM063C	80B5/B14	8012					
	53	121	50	52.48	2590	1.2										
	29	229	50	48.71	3190	0.87										
	36	185	40	39.29	2970	0.97	BKM063B	MV8024	BKM063B	80B5/B14	8024					
	46	143	30	30.31	2720	1.4										
	57	115	25	24.44	2530	1.6										
	69	95	20	20.25	2380	1.6										
	95	69	15	14.67	2130	1.6										
	110	60	12.5	12.67	2030	3.0										
	133	49	10	10.50	1910	3.0										
	184	36	7.5	7.60	1710	3.1										
	30	222	30	30.31	3150	0.9						BKM063B	MV90S6	BKM063B	90B5/B14	90S6
	37	179	25	24.44	2930	1.0										
	44	148	20	20.25	2760	1.0										
	61	107	15	14.67	2470	1.0										
71	93	12.5	12.67	2360	1.9											
86	77	10	10.50	2210	2.0											
118	56	7.5	7.60	1990	2.0											
18.5	348	150	151.20	5040	1.0	BKM075C	MV8012	BKM075C	80B5/B14	8012						
22	290	125	125.95	4750	1.0											
28	228	100	99.22	4380	1.1											
37	174	75	75.45	4000	1.2											
45	144	60	62.43	3750	2.1											
57	113	50	49.18	3470	2.1											
22	287	60	62.43	4730	1.0						BKM075C	MV8024	BKM075C	80B5/B14	8024	
28	226	50	49.18	4370	1.1											
24	280	60	59.44	4660	1.3	BKM075B	MV8024	BKM075B	80B5/B14	8024						
29	227	50	48.18	4340	1.5											
35	189	40	40.13	4080	1.6											
46	142	30	30.24	3720	2.5											
56	119	25	25.19	3500	2.5											
71	93	20	19.84	3230	2.6											
93	71	15	15.09	2950	2.8											
18.7	353	50	48.18	5030	1.0						BKM075B	MV90S6	BKM075B	90B5/B14	90S6	
22	294	40	40.13	4730	1.0											
30	221	30	30.24	4310	1.6											
36	184	25	25.19	4050	1.6											
36	184	25	25.19	4050	1.6											

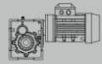
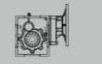

PERFORMANCE PARAMETER

	P_{in} [kW]	n_2 [r/min]	M_{2max} [Nm]	i		F_{r2} [N]	f_s				
				Nominal	Actual						
0.75	45	145	20	19.84	3740	1.7	BKM075B	MV90S6	BKM075B	90B5/B14	90S6
	60	110	15	15.09	3410	1.8					
	72	91	12.5	12.49	3210	3.3					
	91	72	10	9.84	2960	3.3					
	120	55	7.5	7.48	2700	3.7					
	11.6	555	250	240.89	7470	0.9					
	14.0	462	200	200.66	7030	1.0					
	18.5	348	150	151.20	6390	1.4					
	22	290	125	125.95	6010	1.7					
	28	228	100	99.22	5550	1.7					
	37	174	75	75.45	5070	1.7					
	45	144	60	62.43	4760	3.3					
	57	113	50	49.18	4390	3.4					
	11.1	580	125	125.95	7580	0.83	BKM090C	MV8024	BKM090C	80B5/B14	8024
	14.1	457	100	99.22	7000	0.83					
	18.6	247	75	75.45	6390	0.86					
	22	287	60	62.43	6000	1.7					
	28	226	50	49.18	5540	1.7					
24	278	60	59.04	5890	1.8	BKM090B	MV8024	BKM090B	80B5/B14	8024	
29	227	50	48.18	5500	2.2						
35	189	40	40.13	5170	2.5						
46	142	30	30.24	4710	3.5						
56	119	25	25.19	4430	4.0						
71	93	20	19.84	4090	4.1						
93	71	15	15.09	3730	4.2						
14.4	447	60	62.43	6950	1.1	BKM090C	MV90S6	BKM090C	90B5/B14	90S6	
18.3	352	50	49.18	6420	1.1						
15.2	432	60	59.04	6820	1.2	BKM090B	MV90S6	BKM090B	90B5/B14	90S6	
18.7	353	50	48.18	6370	1.4						
22	294	40	40.13	6000	1.6						
30	221	30	30.24	5460	2.3						
36	184	25	25.19	5130	2.6						
45	145	20	19.84	4740	2.6						
60	110	15	15.09	4330	2.7						
9.5	682	300	296.10	8880	1.1						BKM110C
11.5	562	250	244.29	8330	1.3						
13.6	475	200	206.29	7870	1.6						
18.3	353	150	153.33	7130	2.1						
22	298	125	129.48	6740	2.5						
27	239	100	103.64	6260	2.7						

PERFORMANCE PARAMETER

	P_{in} [kW]	n_2 [r/min]	M_{2max} [Nm]	i		F_{r2} [N]	f_s	  								
				Nominal	Actual											
0.75	37	174	75	75.55	5630	3.0	BKM110C	Mv8012	BKM110C	80B5/B14	8012					
	9.1	706	150	153.33	8980	1.1	BKM110C	MV8024	BKM110C	80B5/B14	8024					
	10.8	596	125	129.48	8490	1.3										
	13.5	477	100	103.64	7880	1.4										
	18.5	348	75	75.55	7090	1.5										
	22	296	60	64.18	6720	2.5										
	27	237	50	51.37	6240	2.7										
	24	279	60	59.22	6540	2.7	BKM110B	MV8024	BKM110B	80B5/B14	8024					
	29	230	50	48.86	6130	3.3										
	34	194	40	41.26	5800	3.9										
	8.7	742	100	103.64	9130	0.88	BKM110C	MV90S6	BKM110C	90B5/B14	90S6					
	11.9	541	75	75.55	8220	0.96										
	14.0	460	60	64.18	7780	1.6										
	17.5	368	50	51.37	7230	1.8										
	15.2	434	60	59.22	7580	1.7						BKM110B	MV90S6	BKM110B	90B5/B14	90S6
	18.4	358	50	48.86	7110	2.1										
	22	302	40	41.26	6720	2.5										
	29	225	30	30.67	6090	3.3										
35	190	25	25.90	5750	4.0											
43	152	20	20.73	5340	4.3											
1.1	112	86	12.5	12.47	1770	1.5	BKM050B	MV90S4	BKM050B	90B5/B14	90S4					
	134	72	10	10.47	1670	1.4										
	181	53	7.5	7.73	1510	1.5										
	72	134	12.5	12.47	2050	0.97	BKM050B	MV90L6	BKM050B	90B5/B14	90L6					
	86	112	10	10.47	1930	0.89										
	116	83	7.5	7.73	1750	0.96										
	46	209	30	30.31	2720	0.96	BKM063B	MV90S4	BKM063B	90B5/B14	90S4					
	57	169	25	24.44	2530	1.1										
	69	140	20	20.25	2380	1.1										
	95	101	15	14.67	2130	1.1										
	110	87	12.5	12.67	2030	2.1										
	133	72	10	10.50	1910	2.1										
	184	52	7.5	7.60	1710	2.1	BKM063B	MV90L6	BKM063B	90B5/B14	90L6					
	71	136	12.5	12.67	2360	1.3										
	86	113	10	10.50	2210	1.3										
	118	82	7.5	7.60	1990	1.3	BKM075C	Mv8022	BKM075C	80B5/B14	8022					
	45	211	60	62.43	3750	1.4										
	57	166	50	49.18	3470	1.4										
24	410	60	59.44	4660	0.85	BKM075B	MV90S4	BKM075B	90B5/B14	90S4						
29	333	50	48.18	4340	1.1											

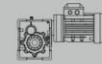
PERFORMANCE PARAMETER

	P_{in} [kW]	n_2 [r/min]	M_{2max} [Nm]	i		F_{r2} [N]	f_s	  			
				Nominal	Actual						
1.1	35	277	40	40.13	4080	1.1	BKM075B	MV90S4	BKM075B	90B5/B14	90S4
	46	209	30	30.24	3720	1.7					
	56	174	25	25.19	3500	1.7					
	71	137	20	19.84	3230	1.8					
	93	104	15	15.09	2950	1.9					
	112	86	12.5	12.49	2770	3.5					
	142	68	10	9.84	2550	3.5					
	187	52	7.5	7.48	2330	3.9					
	30	325	30	30.24	4310	1.1					
	36	271	25	25.19	4050	1.1					
	45	213	10	19.84	3740	1.1					
	60	162	15	15.09	3410	1.2					
	72	134	12.5	12.49	3210	2.2					
	91	106	10	9.84	2960	2.3					
	120	80	7.5	7.48	2700	2.5	BKM090C	MV8022	BKM090C	80B5/B14	8022
	18.5	511	150	151.20	6390	1.0					
	22	425	125	125.95	6010	1.1					
	28	335	100	99.22	5550	1.1					
	37	255	75	75.45	5070	1.2					
	45	211	60	62.43	4760	2.3					
	57	166	50	49.18	4390	2.3	BKM090C	MV90S4	BKM090C	90B5/B14	90S4
	22	422	60	62.43	6000	1.1					
	28	332	50	49.18	5540	1.1					
	24	408	60	59.04	5890	1.2	BKM090B	MV90S4	BKM090B	90B5/B14	90S4
29	333	50	48.18	5500	1.5						
35	277	40	40.13	5170	1.7						
46	209	30	30.24	4710	2.4						
56	174	25	25.19	4430	2.8						
71	137	20	19.84	4090	2.8						
93	104	15	15.09	3730	2.9	BKM090B	MV90L6	BKM090B	90B5/B14	90L6	
15.2	634	60	59.04	6820	0.8						
18.7	517	50	48.18	6370	0.97						
22	431	40	40.13	6000	1.1						
30	325	30	30.24	5460	1.5						
36	271	25	25.19	5130	1.8						
45	213	20	19.84	4740	1.8						
60	162	15	15.09	4330	1.9						
72	134	12.5	12.49	4060	3.6						
91	106	10	9.84	3750	3.6						
120	80	7.5	7.48	3420	3.7						

PERFORMANCE PARAMETER

	P_{in} [kW]	n_2 [r/min]	M_{2max} [Nm]	i		F_{r2} [N]	f_s								
				Nominal	Actual										
1.1	11.5	825	250	244.29	8330	0.91	BKM110C	MV8022	BKM110C	80B5/B14	8022				
	13.6	697	200	206.29	7870	1.1									
	18.3	518	150	153.33	7130	1.4									
	22	437	125	129.48	6740	1.7									
	27	350	100	103.64	6260	1.9									
	37	255	75	75.55	5630	2.0									
	44	217	60	64.18	5330	3.5									
	55	173	50	51.37	4950	3.7									
	BKM110C	10.8	874	125	129.48	8490	0.86	MV90S4	BKM110C	90B5/B14	90S4				
		13.5	700	100	103.64	7880	0.93								
		18.5	510	75	75.55	7090	1.0								
		22	433	60	64.18	6720	1.7								
		27	347	50	51.37	6240	1.9								
		24	409	60	59.22	6540	1.8								
		29	337	50	48.86	6130	2.2								
	BKM110B	34	285	40	41.26	5800	2.6	MV90S4	BKM110B	90B5/B14	90S4				
		46	212	30	30.67	5250	3.5								
		54	179	25	25.90	4960	4.2								
		68	143	20	20.73	4610	4.5								
		14.0	674	60	64.18	7780	1.1								
	BKM110C	17.5	540	50	51.37	7230	1.2	MV90L6	BKM110C	90B5/B14	90L6				
		15.2	636	60	59.22	7580	1.2								
	BKM110B	18.4	525	50	48.86	7110	1.4	MV90L6	BKM110B	90B5/B14	90L6				
		22	443	40	41.26	6720	1.7								
		29	329	30	30.67	6090	2.3								
		35	278	25	25.90	5750	2.7								
		43	223	20	20.73	5340	2.9								
		60	162	15	15.11	4810	3.2								
BKM050B		112	117	12.5	12.47	1770	1.1					MV90L4	BKM050B	90B5/B14	90L4
		134	99	10	10.47	1670	1.0								
		181	73	7.5	7.73	1510	1.1								
BKM063B		57	230	25	24.44	2530	0.8					MV90L4	BKM063B	90B5/B14	90L4
	69	191	20	20.25	2380	0.8									
	95	138	15	14.67	2130	0.8									
	110	119	12.5	12.67	2030	1.5									
	133	99	10	10.50	1910	1.5									
	184	72	7.5	7.60	1710	1.5									
	45	287	60	62.43	3750	1.0									
BKM075C	57	226	50	49.18	3470	1.1	MV90S2	BKM075C	90B5/B14	90S2					
	29	454	50	48.18	4340	0.77									
BKM075B															

PERFORMANCE PARAMETER

	P_{in} [kW]	n_2 [r/min]	M_{2max} [Nm]	i		F_{r2} [N]	f_s								
				Nominal	Actual										
1.5	35	378	40	40.13	4080	0.79	BKM075B	MV90L4	BKM075B	90B5/B14	90L4				
	46	285	30	30.24	3720	1.2									
	56	237	25	25.19	3500	1.3									
	71	187	20	19.84	3230	1.3									
	93	142	15	15.09	2950	1.4									
	112	118	12.5	12.49	2770	2.6									
	142	93	10	9.84	2550	2.6									
	187	70	7.5	7.48	2330	2.8									
	BKM075B	45	291	20	19.84	3740	0.83	MV100L6	BKM075B	100B5/B14	100L6				
		60	221	15	15.09	3410	0.91								
		72	183	12.5	12.49	3210	1.6								
		91	144	10	9.84	2960	1.7								
		120	110	7.5	7.48	2700	1.8								
		22	580	125	125.95	6010	0.83								
		28	457	100	99.22	5550	0.85								
	BKM090C	37	347	75	75.45	5070	0.86	MV90S2	BKM090C	90B5/B14	90S2				
		45	287	60	62.43	4760	1.7								
		57	226	50	49.18	4390	1.7								
		24	556	60	59.04	5890	0.9								
		29	454	50	48.18	5500	1.1								
	BKM090B	35	378	40	40.13	5170	1.3	MV90L4	BKM090B	90B5/B14	90L4				
		46	285	30	30.24	4710	1.8								
		56	237	25	25.19	4430	2.0								
		71	187	20	19.84	4090	2.0								
		93	142	15	15.09	3730	2.1								
		112	118	12.5	12.49	3510	4.1								
		142	93	10	9.84	3240	4.1								
		187	70	7.5	7.48	2950	4.3								
BKM090B		30	443	30	30.24	5460	1.1					MV100L6	BKM090B	100B5/B14	100L6
		36	369	25	25.19	5130	1.3								
	45	291	20	19.84	4740	1.3									
	60	221	15	15.09	4330	1.4									
	72	183	12.5	12.49	4060	2.6									
	91	144	10	9.84	3750	2.6									
	120	110	7.5	7.48	3420	2.7									
BKM110C	18.3	706	150	153.33	7130	1.1	MV90S2	BKM110C	90B5/B14	90S2					
	22	596	125	129.48	6740	1.3									
	27	477	100	103.64	6260	1.4									
	37	348	75	75.55	5630	1.5									
	44	296	60	64.18	5330	2.5									

PERFORMANCE PARAMETER

P _{in} [kW]	n ₂ [r/min]	M _{2max} [Nm]	i		F _{r2} [N]	fs						
			Nominal	Actual								
1.5	55	237	50	51.37	4950	2.7	BKM110C	MV90S2	BKM110C	90B5/B14	90S2	
	22	591	60	64.18	6720	1.3	BKM110C	MV90L4	BKM110C	90B5/B14	90L4	
	27	473	50	51.37	6240	1.4						
	24	557	60	59.22	6540	1.3						
	29	460	50	48.86	6130	1.6	BKM110B	MV90L4	BKM110B	BKM110B	90L4	
	34	388	40	41.26	5800	1.9						
	46	289	30	30.67	5250	2.6						
	54	244	25	25.90	4960	3.1						
	68	195	20	20.73	4610	3.3						
	93	142	15	15.11	4150	3.7						
	15.2	867	60	59.22	7580	0.86						
	18.4	715	50	48.86	7110	1.0	BKM110B	MV100L6	BKM110B	100B5/B14	100L6	
	22	604	40	41.26	6720	1.2						
	29	449	30	30.67	6090	1.7						
	35	379	25	25.90	5750	2.0						
43	304	20	20.73	5340	2.1							
60	221	16	15.11	4810	2.4							
70	188	12.5	12.84	4550	4.0							
88	150	10	10.27	4220	4.3							
120	110	7.5	7.49	3800	4.7							
2.2	46	418	30	30.24	3720	0.84						BKM075B
	56	348	25	25.19	3500	0.86						
	71	274	20	19.84	3230	0.88						
	93	208	15	15.09	2950	0.96						
	112	172	12.5	12.49	2770	1.7						
	142	136	10	9.84	2550	1.8						
	187	103	7.5	7.48	2330	1.9						
	72	268	12.5	12.49	3210	1.1	BKM075B	MV112M6	BKM075B	112B5/B14	112M6	
	91	211	10	9.84	2960	1.1						
	120	161	7.5	7.48	2700	1.2						
	3.0	45	422	60	62.43	4760	1.1	BKM090C	MV90L2	BKM090C	90B5/B14	90L2
		57	332	50	49.18	4390	1.1					
		35	554	40	40.13	5170	0.87					
		46	418	30	30.24	4710	1.2					
		56	348	25	25.19	4430	1.4					
		71	274	20	19.84	4090	1.4					
		93	208	15	15.09	3730	1.4					
		112	172	12.5	12.49	3510	2.8					
142		136	10	9.84	3240	2.8						
187		103	7.5	7.48	2950	2.9						

PERFORMANCE PARAMETER

P _{in} [kW]	n ₂ [r/min]	M _{2max} [Nm]	i		F _{r2} [N]	fs										
			Nominal	Actual												
2.2	36	541	25	25.19	5130	0.9	BKM090B	MV112M6	BKM090B	112B5/B14	112M6					
	45	426	20	19.84	4740	0.9										
	60	324	15	15.09	4330	0.93										
	72	268	12.5	12.49	4060	1.8										
	91	211	10	9.84	3750	1.8										
	120	161	7.5	7.48	3420	1.9										
	22	874	125	129.48	6740	0.86	BKM110C	MV90L2	BKM110C	90B5/B14	90L2					
	27	700	100	103.64	6260	0.93										
	37	510	75	75.55	5630	1.0										
	44	433	60	64.18	5330	1.7										
	55	347	50	51.37	4950	1.9										
	24	818	60	59.22	6540	0.92						BKM110B	MV100L1-4	BKM110B	100B5/B14	100L1-4
	29	675	50	48.86	6130	1.1										
	34	570	40	41.26	5800	1.3										
	46	423	30	30.67	5250	1.8										
54	358	25	25.90	4960	2.1											
68	286	20	20.73	4610	2.3											
93	209	15	15.11	4150	2.5											
109	177	12.5	12.84	3930	4.2											
136	142	10	10.27	3650	4.6											
187	103	7.5	7.49	3280	5.0											
3.0	29	659	30	30.67	6090	1.1	BKM110B	MV112M6	BKM110B	112B5/B14	112M6					
	35	556	25	25.90	5750	1.3										
	43	445	20	20.73	5340	1.5										
	60	325	15	15.11	4810	1.6										
	70	276	12.5	12.84	4550	2.7										
	88	221	10	10.27	4220	2.9										
	120	161	7.5	7.49	3800	3.2										
	112	235	12.5	12.49	2770	1.3	BKM075B	MV100L2-4	BKM075B	100B5/B14	100L2-4					
	142	185	10	9.84	2550	1.3										
	187	141	7.5	7.48	2330	1.4										
	3.0	46	569	30	30.24	4710	0.9	BKM090B	MV100L2-4	BKM090B	100B5/B14	100L2-4				
		56	474	25	25.19	4430	1.0									
		71	374	20	19.84	4090	1.0									
		93	284	15	15.09	3730	1.1									
		112	235	12.5	12.49	3510	2.0									
142		185	10	9.84	3240	2.1										
187		141	7.5	7.48	2950	2.1										
44		591	60	64.18	5330	1.3	BKM110C						MV100L2	BKM110C	100B5/B14	100L2
55		473	50	51.37	4950	1.4										

PERFORMANCE PARAMETER

P _{in} [kW]	n ₂ [r/min]	M _{2max} [Nm]	i		F _{r2} [N]	fs							
			Nominal	Actual									
3.0	34	777	40	41.26	5800	0.97	BKM110B	MV100L2-4	BKM110B	100B5/B14	100L2-4		
	46	577	30	30.67	5250	1.3							
	54	488	25	25.90	4960	1.5							
	68	390	20	20.73	4610	1.7							
	93	284	15	15.11	4150	1.8							
	109	242	12.5	12.84	3930	3.1							
	136	193	10	10.27	3650	3.4							
	187	141	7.5	7.49	3280	3.7							
	3.0	35	759	25	25.90	5750	1.0	BKM110B	MV132S6	BKM110B	132B5	132S6	
		43	607	20	20.73	5340	1.1						
		60	443	15	15.11	4810	1.2						
		70	376	12.5	12.84	4550	2.0						
		88	301	10	10.27	4220	2.2						
		120	219	7.5	7.49	3800	2.4						
4.0	112	314	12.5	12.49	2770	0.96	BKM075B	MV112M4	BKM075B	112B5/B14	112M4		
	142	247	10	9.84	2550	1.0							
	187	188	7.5	7.48	2330	1.1							
	4.0	112	314	12.5	12.49	3510	1.5	BKM090B	MV112M4	BKM090B	112B5/B14	112M4	
		142	247	10	9.84	3240	1.5						
		187	188	7.5	7.48	2950	1.6						
		46	770	30	30.67	5250	1.0						
		4.0	54	650	25	25.90	4960	1.2	BKM110B	MV112M4	BKM110B	112B5/B14	112M4
			68	520	20	20.73	4610	1.2					
			93	379	15	15.11	4150	1.4					
109	322		12.5	12.84	3930	2.3							
136	258		10	10.27	3650	2.5							
187	188		7.5	7.49	3280	2.8							
5.5	68	716	20	20.73	4610	0.9	BKM110B	MV132S4	BKM110B	132B5	132S4		
	93	522	15	15.11	4150	1.0							
	109	443	12.5	12.84	3930	1.7							
	136	354	10	10.27	3650	1.8							
	187	259	7.5	7.49	3280	2.0							

PERFORMANCE PARAMETER
BKM.. HS / Performance parameter

 n₁ = 1400r/min

M _{2max} [Nm]	n ₂ [r/min]	i Nominal	i Actual	P _{1in} [kW]	F _{r2} [N]	F _{r1} [N]	
130	4.8	300	291.79	0.07	4100	400	BKM050C..HS
130	5.7	250	244.29	0.09	4100	400	
130	7.0	200	200.44	0.11	4100	400	
130	9.5	150	146.67	0.14	4000	400	
130	11.6	125	120.34	0.18	3770	400	
100	13.9	100	101.04	0.16	3560	400	
80	18.8	75	74.62	0.17	3220	400	
130	22	60	62.36	0.34	3030	400	
100	27	50	52.36	0.31	2860	400	
130	24	60	58.36	0.35	2960	400	
130	29	50	48.86	0.42	2790	400	
130	35	40	40.09	0.52	2610	400	
130	48	30	29.33	0.71	2350	400	
130	58	25	24.07	0.86	2200	400	
100	69	20	20.21	0.79	2080	400	
80	94	15	14.92	0.85	1880	400	
130	112	12.5	12.47	1.7	1770	400	
100	134	10	10.47	1.5	1670	400	
80	181	7.5	7.73	1.6	1510	400	
200	4.6	300	302.50	0.11	4800	400	BKM063C..HS
200	5.7	250	243.57	0.13	4800	400	
180	7.1	200	196.43	0.15	4800	400	
200	9.2	150	151.56	0.21	4650	400	
180	11.5	125	122.22	0.24	4330	400	
150	13.8	100	101.27	0.24	4070	400	
110	19.1	75	73.33	0.24	3650	400	
180	22	60	63.33	0.46	3480	400	
150	27	50	52.48	0.47	3270	400	
200	23	60	60.50	0.53	3430	530	
200	29	50	48.71	0.65	3190	530	
180	36	40	39.29	0.73	2970	530	
200	46	30	30.31	1.1	2720	530	
180	57	25	24.44	1.2	2530	530	
150	69	20	20.25	1.2	2380	530	
110	95	15	14.67	1.2	2130	530	
180	110	12.5	12.67	2.3	2030	530	
150	133	10	10.50	2.3	1910	530	
110	184	7.5	7.60	2.3	1710	530	

OUTLINE DIMENSION SHEET

BKM..IEC / Outline Dimension

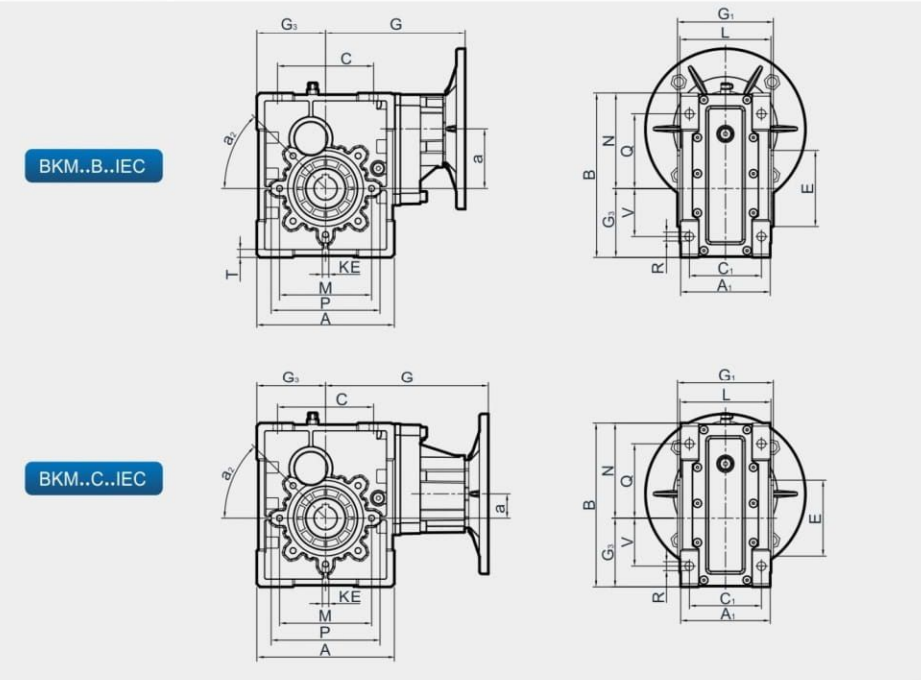

BKM	C	A	B	G	G ₃	a	C ₁	KE	a ₂	L	G ₁	M	E ₃₀	A1	R	P	Q	N	T	V	kg
050B	80	120	155	132.5	60	57	70	4-M8*12	45°	87	92	85	70	85	8.5	100	75	95	7	40	4.5
050C	80	120	155	148	60	21.5	70	4-M8*12	45°	87	92	85	70	85	8.5	100	75	95	7	40	5
063B	100	144	174	143.5	72	64.5	85	7-M8*14	45°	106	112	95	80	103	8.5	110	80	102	8	50	6.3
063C	100	144	174	169	72	29	85	7-M8*14	45°	106	112	95	80	103	8.5	110	80	102	8	50	7
075B	120	172	205	174	86	74.5	90	7-M8*16	45°	114	120	115	95	112	11	140	93	119	10	60	9.9
075C	120	172	205	203	86	30.5	90	7-M8*16	45°	114	120	115	95	112	11	140	93	119	10	60	10.9
090B	140	206	238	192	103	88	100	7-M10*22	45°	134	140	130	110	130	13	160	102	135	11	70	13.9
090C	140	206	238	220	103	44	100	7-M10*22	45°	134	140	130	110	130	13	160	102	135	11	70	14.9
110B	170	255	295	241.5	127.5	108	115	7-M10*25	45°	148	155	165	130	144	14	185	125	167.5	13	85	28
110C	170	255	295	271.5	127.5	52	155	7-M10*25	45°	148	155	165	130	144	14	185	125	167.5	13	85	30

Note:Weight(kg) without the weight of motor.

OUTLINE DIMENSION SHEET

BKM..MV.. Outline Dimension

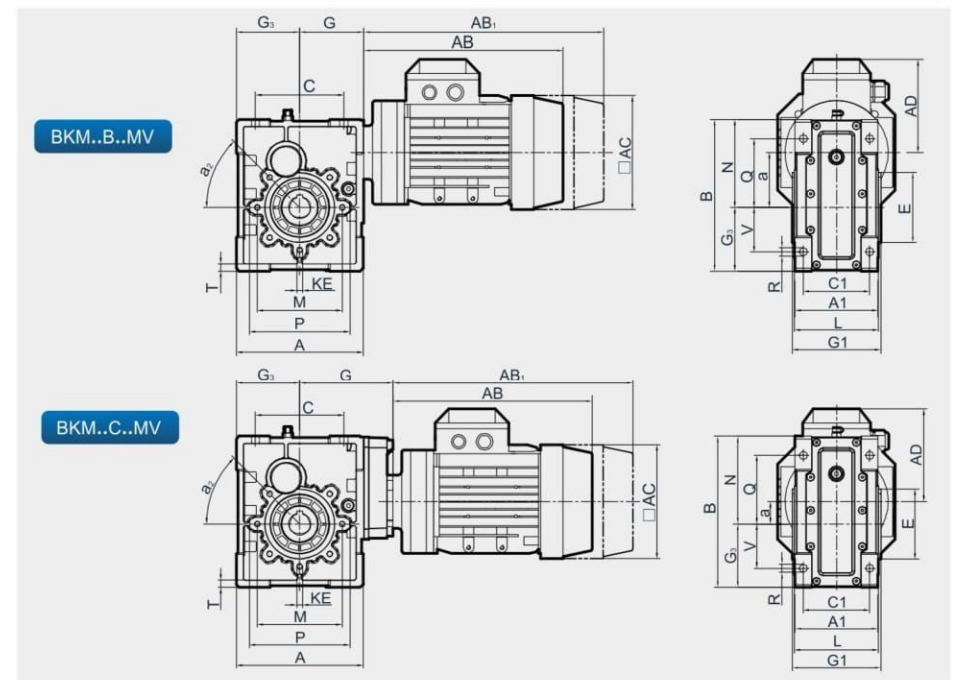

BKM	C	A	B	G	G ₃	a	C ₁	KE	a ₂	L	G ₁	M	E ₃₀	A1	R	P	Q	N	T	V
050B	80	120	155	61	60	57	70	4-M8*12	45°	87	92	85	70	85	8.5	100	75	95	7	40
050C	80	120	155	95	60	21.5	70	4-M8*12	45°	87	92	85	70	85	8.5	100	75	95	7	40
063B	100	144	174	72	72	64.5	85	7-M8*14	45°	106	112	95	80	103	8.5	110	80	102	8	50
063C	100	144	174	106	72	29	85	7-M8*14	45°	106	112	95	80	103	8.5	110	80	102	8	50
075B	120	172	205	87	86	74.5	90	7-M8*16	45°	114	120	115	95	112	11	140	93	119	10	60
075C	120	172	205	126	86	30.5	90	7-M8*16	45°	114	120	115	95	112	11	140	93	119	10	60
090B	140	206	238	104	103	88	100	7-M10*22	45°	134	140	130	110	130	13	160	102	135	11	70
090C	140	206	238	143	103	44	100	7-M10*22	45°	134	140	130	110	130	13	160	102	135	11	70
110B	170	255	295	127.5	127.5	108	115	7-M10*25	45°	148	155	165	130	144	14	185	125	167.5	13	85
110C	170	255	295	177.5	127.5	52	155	7-M10*25	45°	148	155	165	130	144	14	185	125	167.5	13	85

MV..	63	71	80	90S	90L	100	112	132
AB	211	226	261	285	295	355	373	424
AB1	266	290	354	370	380	440	453	504
AC	120	130	145	160	160	185	200	245
AD	104	109	110	115	115	140	158	178

OUTLINE DIMENSION SHEET

BKM..NEMA Input Flange Dimension

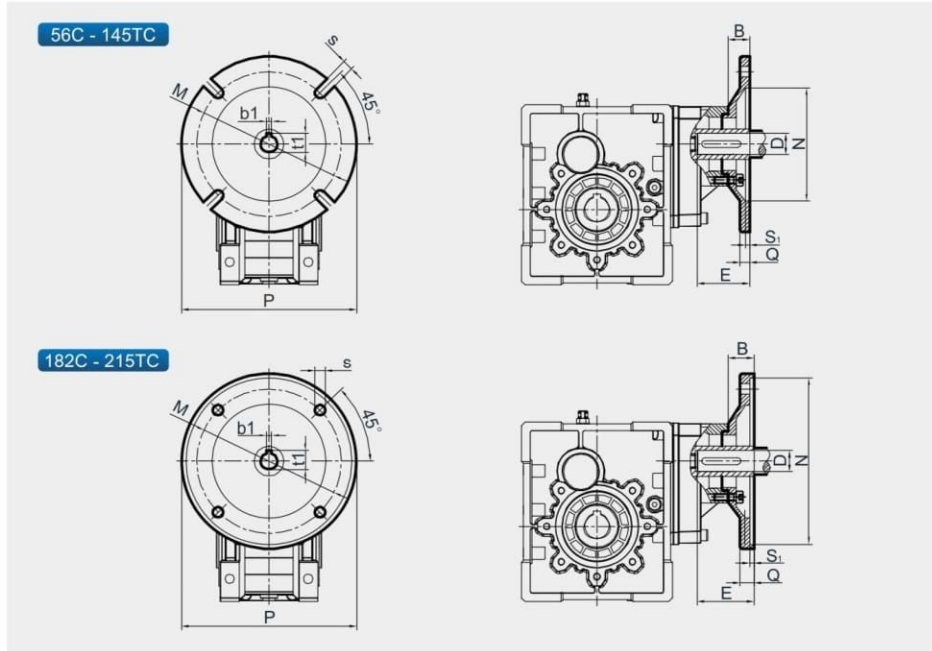

BKM	NEMA Flange	B	D	E	b1	t1	M	N	P	Q	S	S1
050	56C	1.15	0.625	2.06	0.188	0.713	5.875	4.5	6.5	0.433	0.413	0.177
	145TC	1.22	0.625	2.06	0.188	0.713	5.875	4.5	6.5	0.433	0.413	0.177
063	143TC	1.22	0.875	2.12	0.188	0.963	5.875	4.5	6.5	0.433	0.413	0.177
	145TC											
075	56C	1.50	0.625	2.06	0.188	0.713	5.875	4.5	6.5	0.433	0.413	0.177
	145TC	1.50	0.875	2.12	0.188	0.963	5.875	4.5	6.5	0.433	0.413	0.177
090	182TC	1.50	1.126	2.62	0.250	1.240	7.250	8.5	9.0	0.472	0.551	0.197
	184TC											
110	56C	1.89	0.625	2.06	0.188	0.713	5.875	4.5	6.5	0.433	0.413	0.177
	143TC	1.89	0.875	2.12	0.188	0.983	5.875	4.5	6.5	0.433	0.413	0.177
	145TC											
	182TC	1.89	1.125	2.62	0.250	1.240	7.250	8.5	9.0	0.472	0.551	0.197
	184TC											
	213TC	1.89	1.375	3.12	0.312	1.517	7.250	8.5	9.0	0.472	0.551	0.197
215TC												

OUTLINE DIMENSION SHEET

BKM..ST Servo Motor Input Flange Dimension

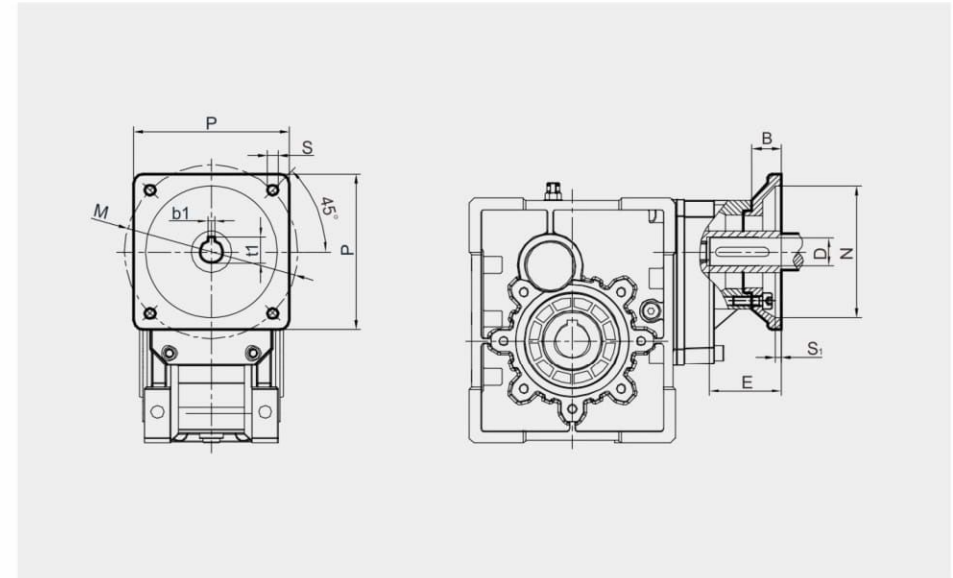

BKM	P	B	D _v	E	b1	t1	M	N	S	S1
050	60	35	14	30	5	16.3	70	50	5.5	4
	80	28	19	35	6	21.8	90	70	6	5
	90	30	16	35	5	18.3	100	80	6.5	5
	110	26	19	55	6	21.8	130	95	9	6
063	60	40	14	30	5	16.3	70	50	5.5	4
	80	21	19	35	6	21.8	90	70	6	5
	90	21	16	35	5	18.3	100	80	6.5	5
	110	46	19	55	6	21.8	130	95	9	6
075	60	40	22	57	6	24.8	145	110	9	6
	110	47	19	55	6	21.8	130	95	9	6
	130	40	22	57	6	24.8	145	110	9	6
	150	38	28	58	8	31.3	165	130	11	6
090	110	47	19	55	6	21.8	130	95	9	6
	130	40	22	57	6	24.8	145	110	9	6
	150	38	28	58	8	31.3	165	130	11	6
110	130	38	22	57	6	24.8	145	110	9	6
	150	38	28	58	8	31.3	165	130	11	6
	180	38	35	65	10	38.3	200	114.3	13.5	6

ACCESSORIES OUTLINE DIMENSION SHEET

Output Shafts

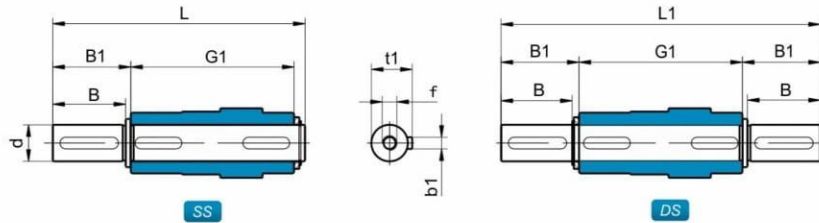

BKM	d_{h6}	B	B1	G1	L	L1	f	b1	t1
050	25	50	53.5	92	153	199	M10*27	8	28
063	25	50	53.5	112	173	219	M10*27	8	28
075	28	60	63.5	120	192	247	M10*27	8	31
090	35	80	84.5	140	234	309	M12*34	10	38
110	42	80	84.5	155	249	324	M16*42	12	45

Torque Arm

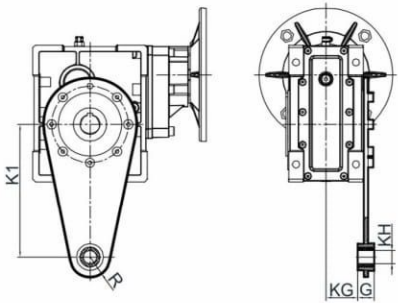

BKM	K1	G	KG	KH	R
050	100	14	38.5	10	18
063	150	14	49	10	18
075	200	25	47.5	20	30
090	200	25	57.5	20	30
110	250	30	62	25	35

Cover

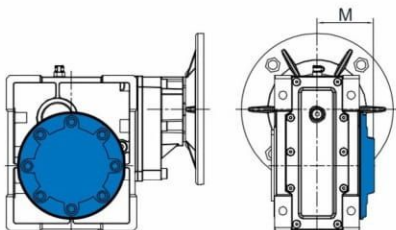

BKM	M
050	58
063	69
075	74
090	86
110	94

ACCESSORIES OUTLINE DIMENSION SHEET

Position diagram for output flange

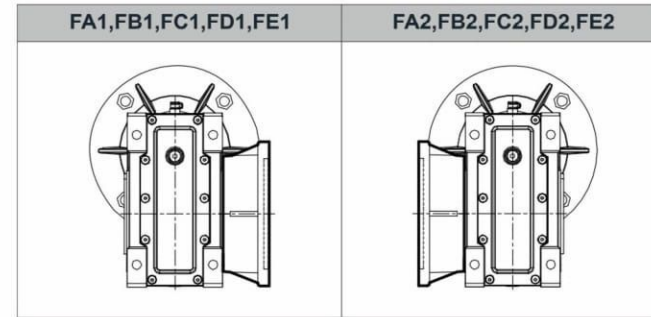

Unless specified otherwise, the gear units is supplied with the flange in pos. **F.1** referred to position **B3**.

Position diagram for single output shaft

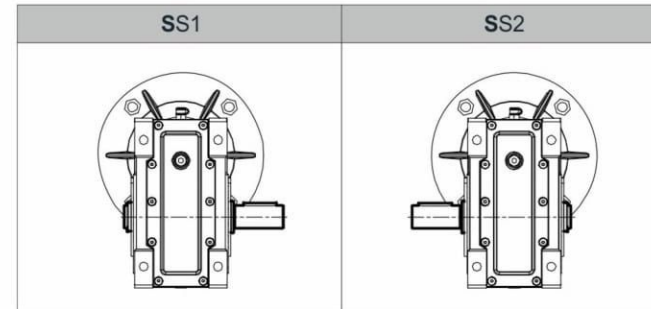

Unless specified otherwise, the gear units is supplied with the flange in pos. **SS1** referred to position **B3**.

Position of motor terminal box

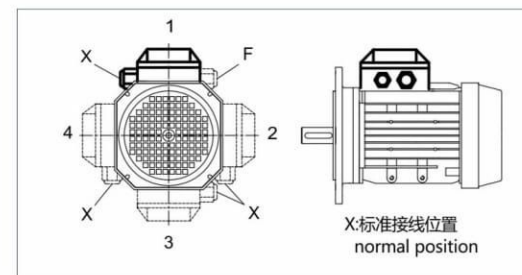

Symbols Used

Symbol	Meaning
	Breather valve
	Oil level plug
	Oil drain plug

INSTALLATION POSITIONS DIAGRAM

BKM..Mounting Positions

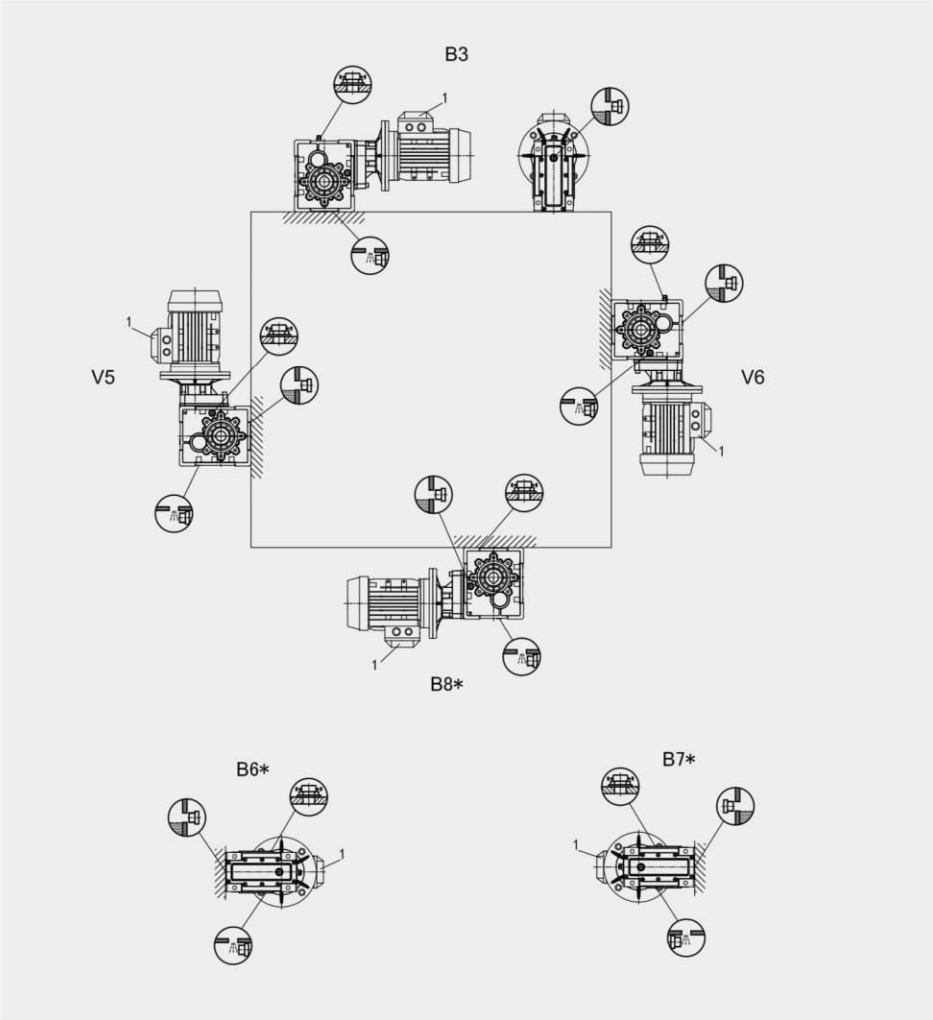

● It means the lubricant can't be added according to the oil level line plug, but also higher the plug the fill quantity sa shown in the table.

INSTALLATION POSITIONS DIAGRAM

Direction of rotation



The motor can be run either CW or CCW while using with gearbox, the above chart is recommended.